

Antena horn piramidala si  

---

antena horn circulara



## Enunțul lucrării

- Să se modeleze și analizeze o antenă de tip horn piramidală folosind Ansoft HFSS.

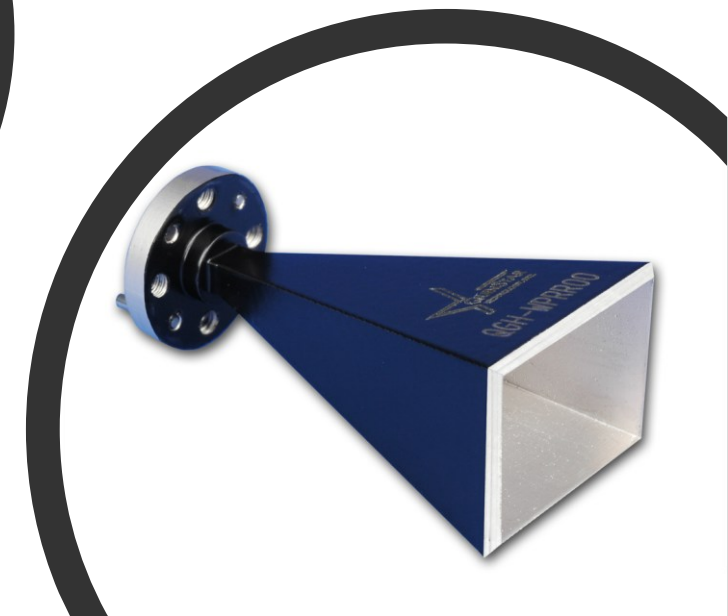
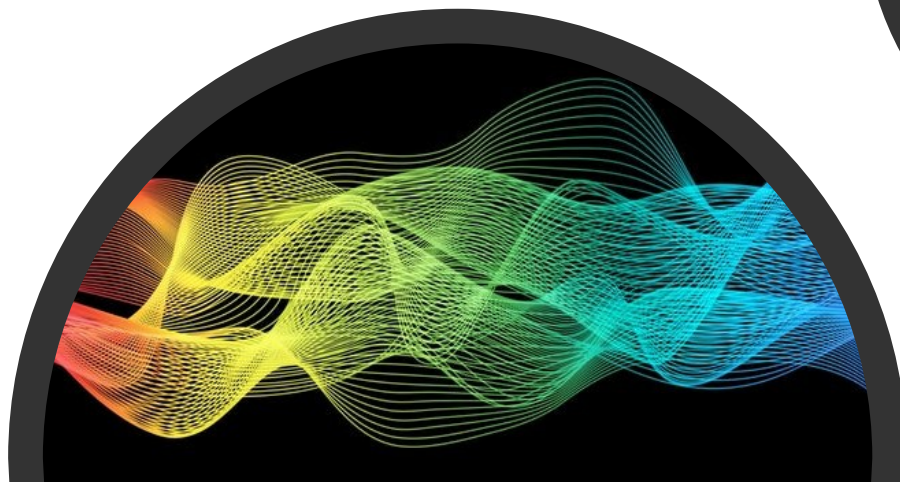
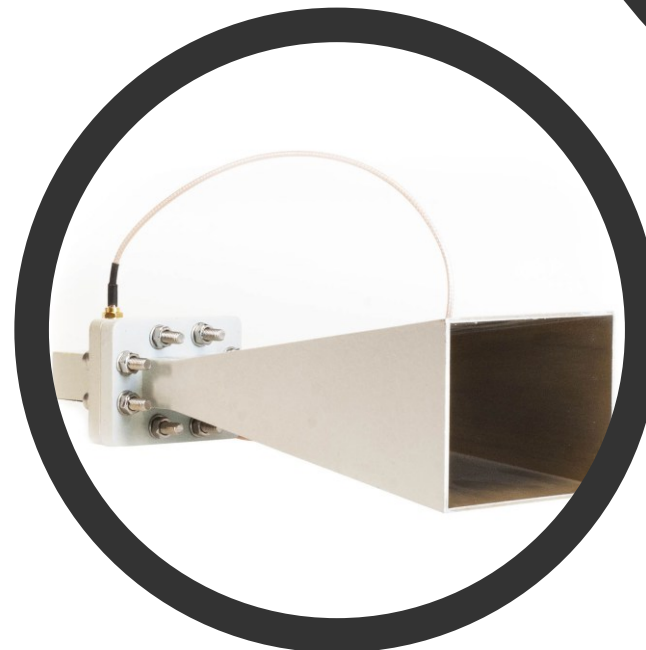
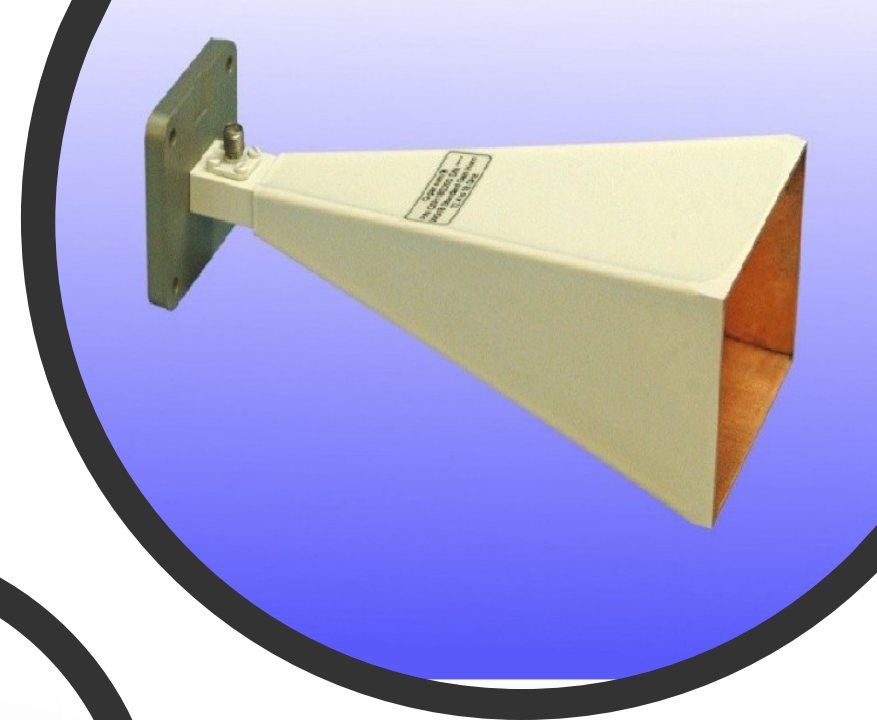

# Enunțul lucrării

Model	Frequency (GHz)	Waveguide	Gain (dB)	Figure	Size L×W×H (mm)	Material
CESGH-62-20	12.4-18.0	WR62	20	A	135×93×72	Al/Cu
				B	145×93×72	
				C	175×93×72	

## WR62 Specifications

Recommended Frequency Band:	12.40 to 18 GHz
Cutoff Frequency of Lowest Order Mode:	9.488 GHz
Cutoff Frequency of Upper Mode:	18.976 GHz
Dimension:	0.622 Inches [15.7988 mm] x 0.311 Inches [7.8994 mm]

[https://www.compeng.com.au/document-library/standard-gain-horn-antennas/?fbclid=IwAR0loKoFoypstXakwg\\_gW4ElpcUfnHMGirJAQC6RhraZW Cvn1uOLBiqfMIA](https://www.compeng.com.au/document-library/standard-gain-horn-antennas/?fbclid=IwAR0loKoFoypstXakwg_gW4ElpcUfnHMGirJAQC6RhraZW Cvn1uOLBiqfMIA)



Figure A:

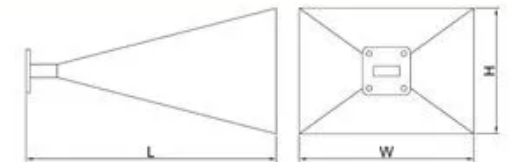

<https://www.everythingrf.com/tech-resources/waveguides-sizes/wr62>

## Obiectivele lucrării

- Modelarea unei antene horn piramidale
- Determinarea câștigului ca polar plot
- Determinarea radiației rE ca polar plot
- Reprezentarea parametrilor S
- Determinarea distribuției de camp electric pe planul XY
- Determinarea distribuției de camp electric pe planul YZ
- Determinarea distribuției de camp magnetic pe planul XY
- Determinarea distribuției de camp magnetic pe planul YZ
- Reprezentarea radiației

# Implementarea modelului pentru modelare numerică

- Se deschide Ansys Electronics Desktop



- Se va alege să se modeleze un proiect HFSS

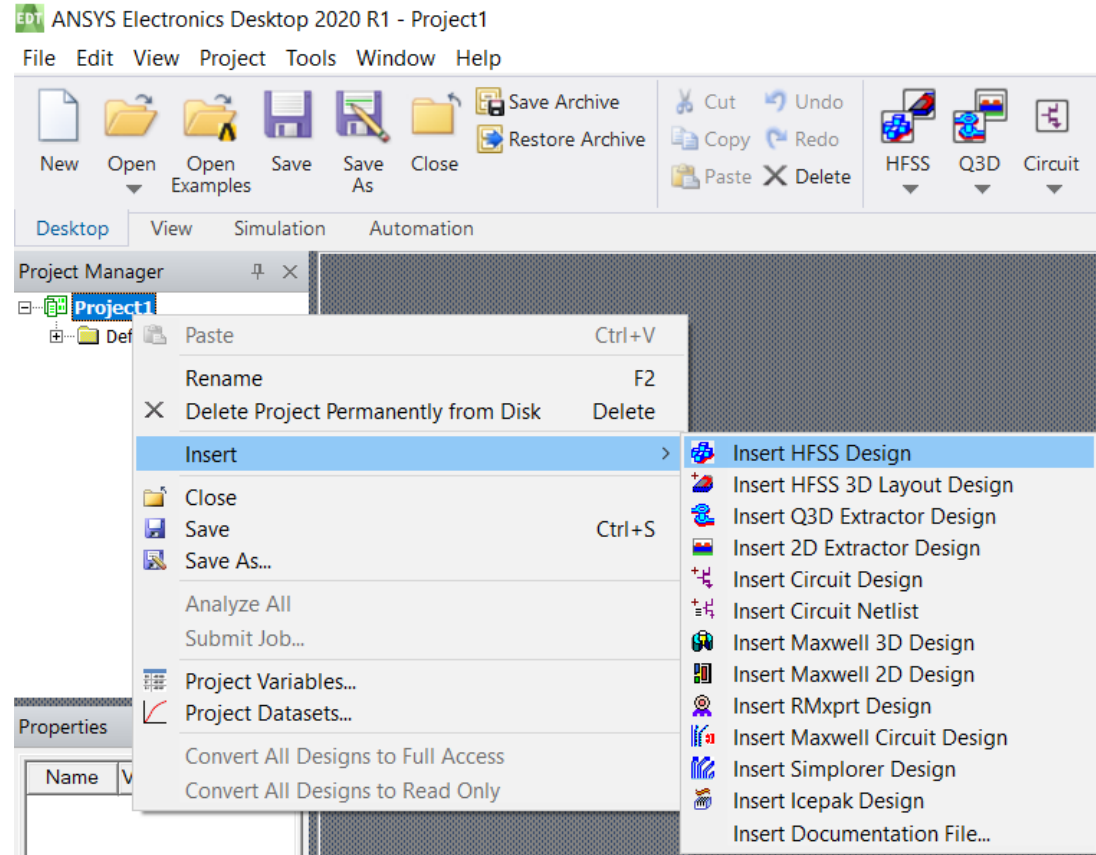
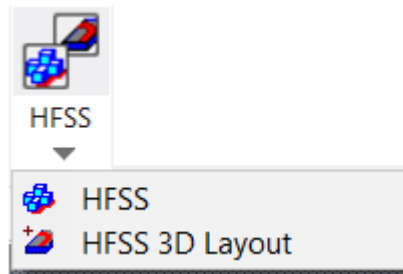

# Implementarea modelului pentru modelare numerică

- Vom alege unitatea de măsură pentru model din Modeler ->Units...

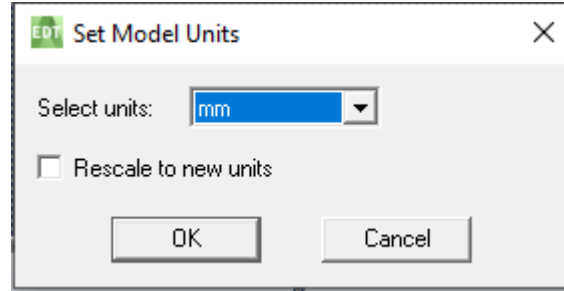

- Vom alege tipul soluției din HFSS->Solution Type

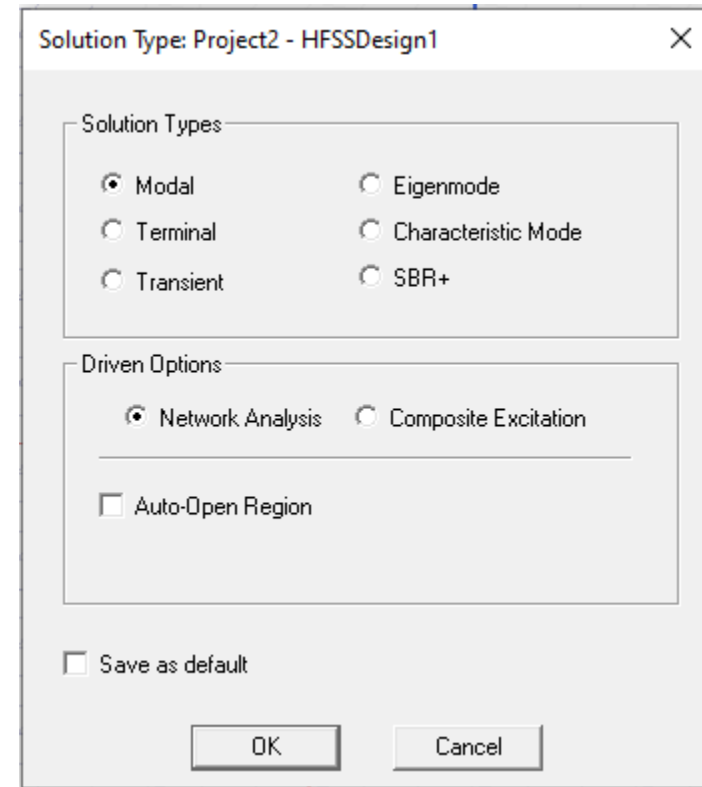

# Implementarea antenei de tip horn

## Desenarea ghidului de undă

- Desenăm un box, după cum urmează:

Add Variable

Name: lungimehorn

Unit Type: Length

Unit: mm

Value: 100

Type: Local Variable

OK Cancel

Add Variable

Name: a

Unit Type: Length

Unit: mm

Value: 15.7988

Type: Local Variable

OK Cancel

Add Variable

Name: b

Unit Type: Length

Unit: mm

Value: 7.8994

Type: Local Variable

OK Cancel

Properties: hornnou - HFSSDesign1 - Modeler

Command

Name	Value	Unit	Evaluated Value	Description
Command	CreateBox			
Coordinate Sys...	Global			
Position	lungimehorn ,a/2 ,b/2		100mm , 7.899...	
XSize	lungimeghiddeunda		35mm	
YSize	a		15.7988mm	
ZSize	b		7.8994mm	

Show Hidden

OK Cancel Apply

lungimehorn	100	mm
a	15.7988	mm
b	7.8994	mm
lungimeghiddeunda	35	mm

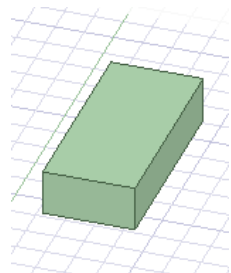

# Implementarea antenei de tip horn

## Desenarea deschiderii hornului

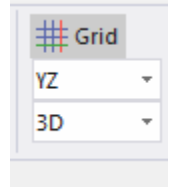

- Se va desena un dreptunghi în planul YZ reprezentând deschiderea antenei

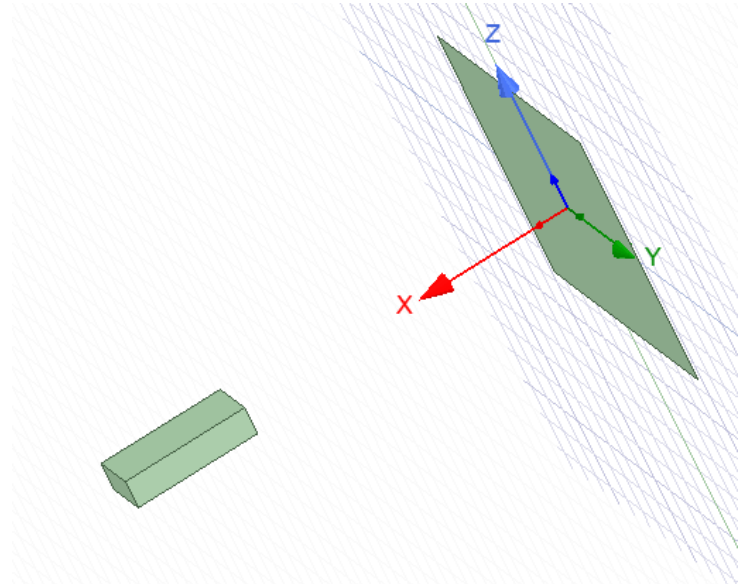
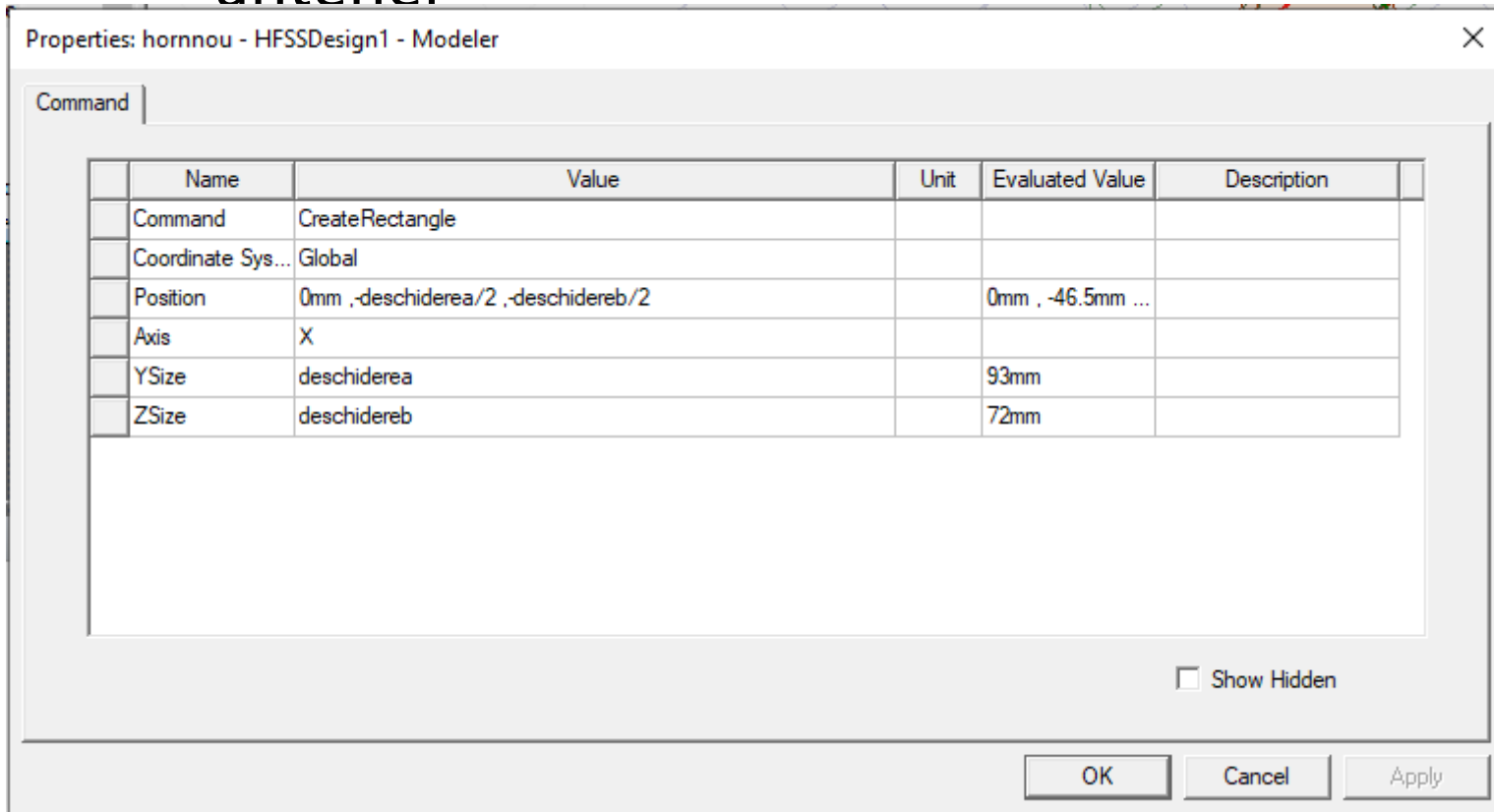

deschiderea	93	mm
deschidereb	72	mm

# Implementarea antenei de tip horn

## Desenarea deschiderii hornului

- Se va selecta Edit-> Select Faces si se va alege aceasta fata

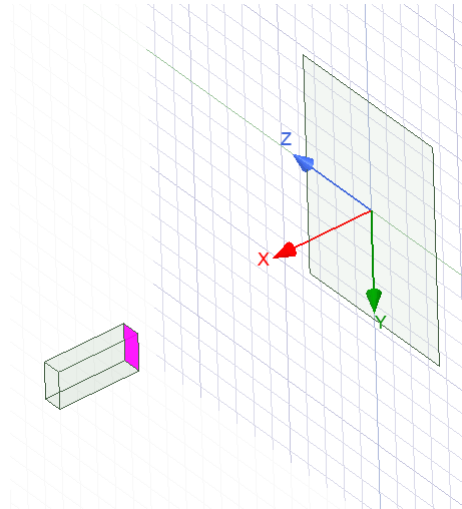

- Se va accesa Modeler->Surface->Create object from face

# Implementarea antenei de tip horn

## Desenarea deschiderii hornului

- Se va trece la selection mode la modul de selectie object
- Se selecteaza noul element creat si dreptunghiul creat pentru deschidere si se va selecta modeler->surface ->connect

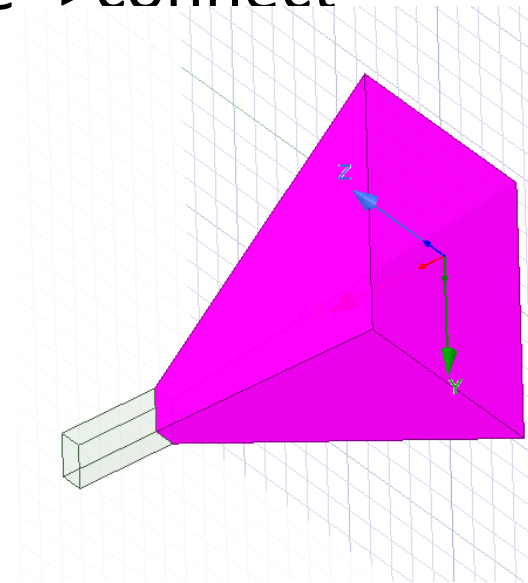
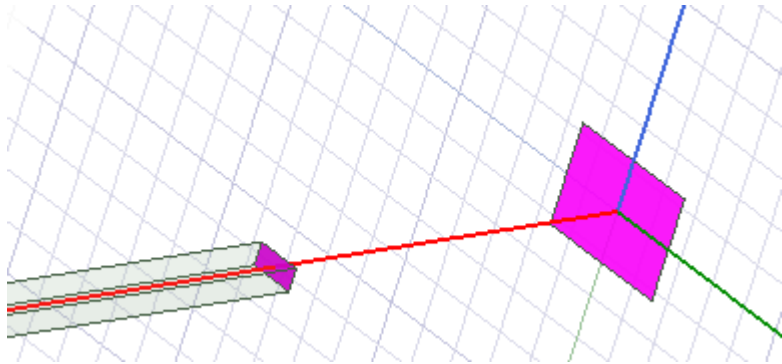

- Se selecteaza toate obiectele create in acest model si se va da Modeler ->Boolean->Unite

# Observarea parametrilor modelului

- Pentru a vedea lista de variabile fie accesam HFSS->design properties

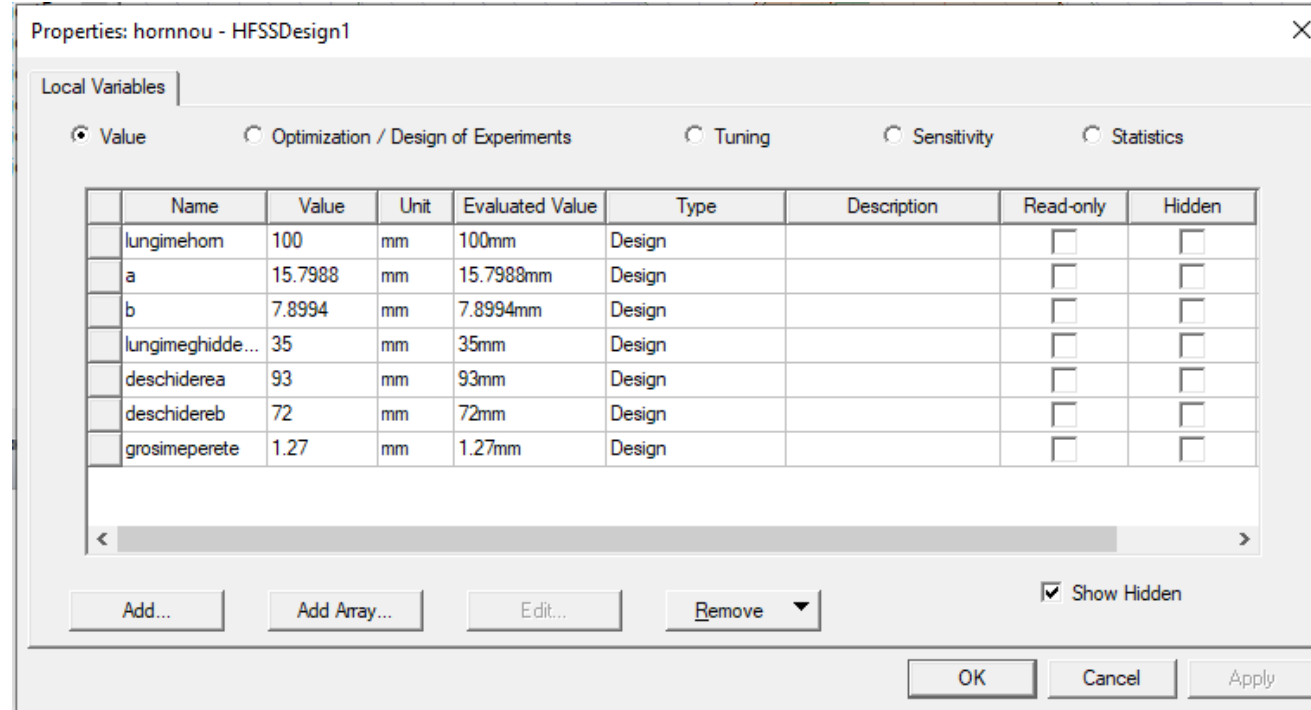

- Fie mergem pe design in project manager si se deschide in fereastra de Properties o lista cu acestea; astfel valorile pot fi modificate in orice moment al modelarii

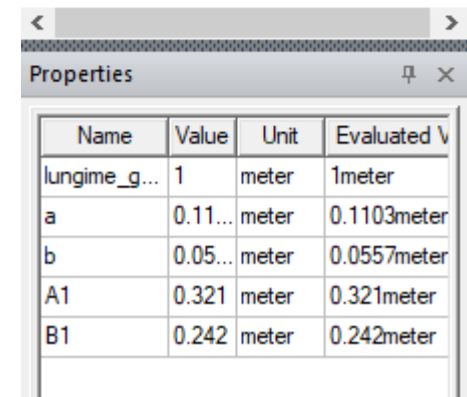
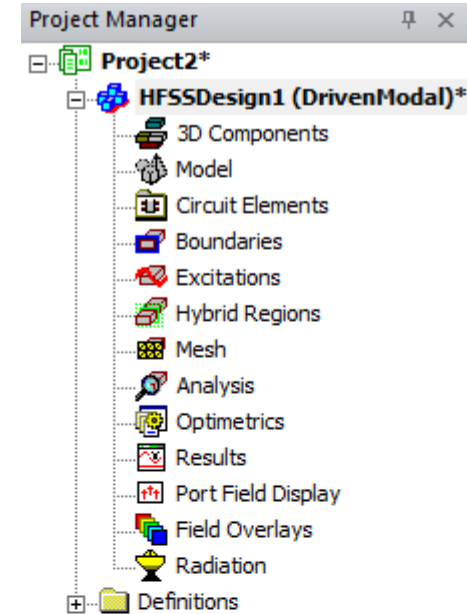

## Crearea stratului de metal

- Vom trece iar la tipul de selectie fețe deci Edit->Selection Mode->Faces
- Edit->Select objects->By Name permite selectarea specifica a fetelor; vom allege toate fetele, excluzand doar cea mai mare dintre ele si anume cea de la iesire din Horn

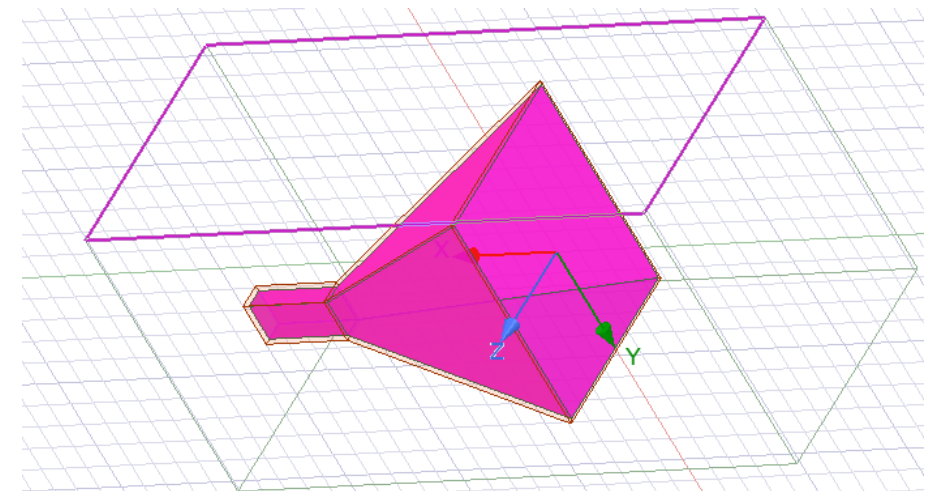
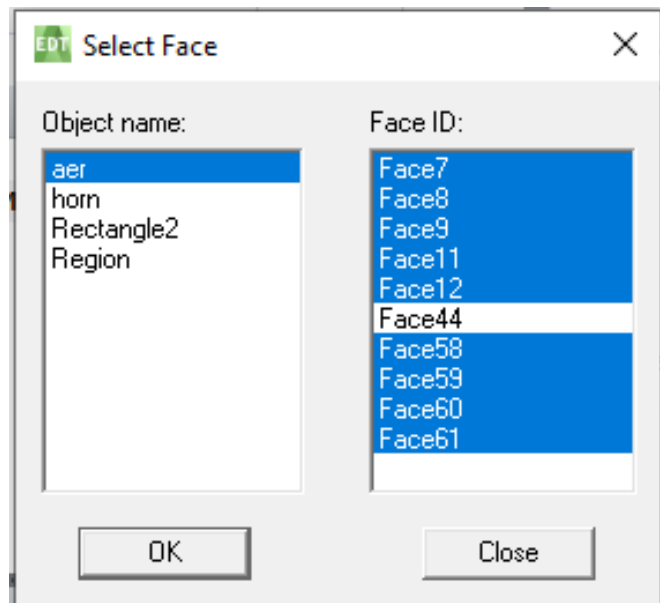

## Crearea stratului de metal

- Cu suprafețele selectate, vom apela Modeler->Surface->Create Object From Face
- Modeler->Boolean ->Unite va crea din toate fețele nou create un nou element
- Modeler->Surface->Thicken Sheet va permite introducerea unei noi grosimi

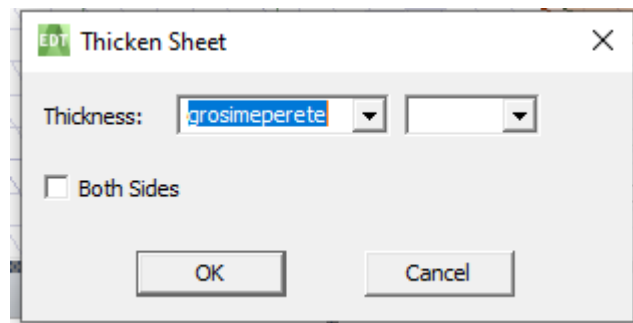

grosimeperete	1.27	mm
---------------	------	----

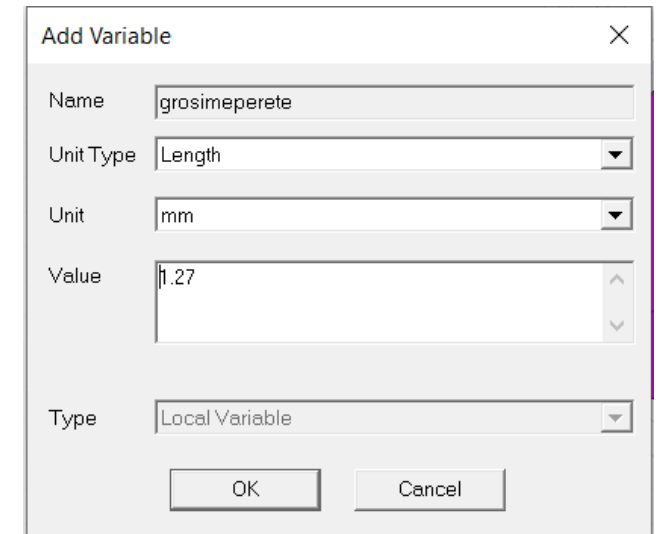

# Implementarea antenei de tip horn

## Atribuirea materialelor

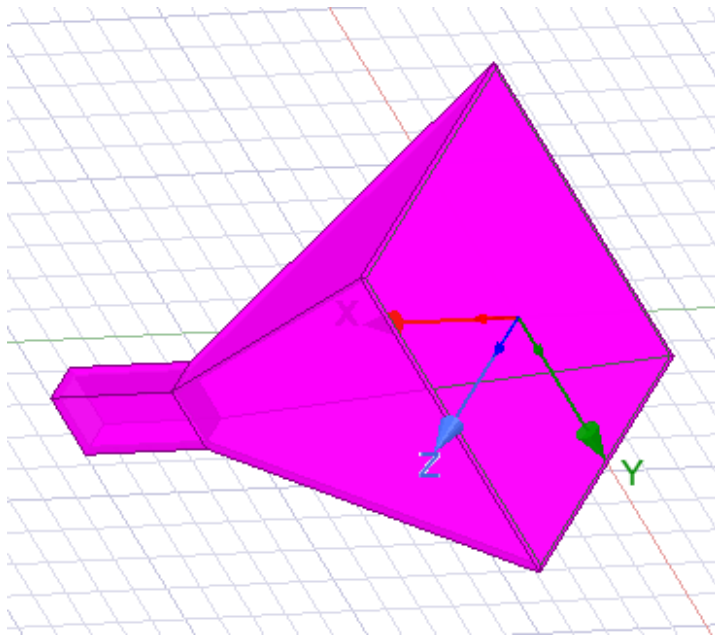
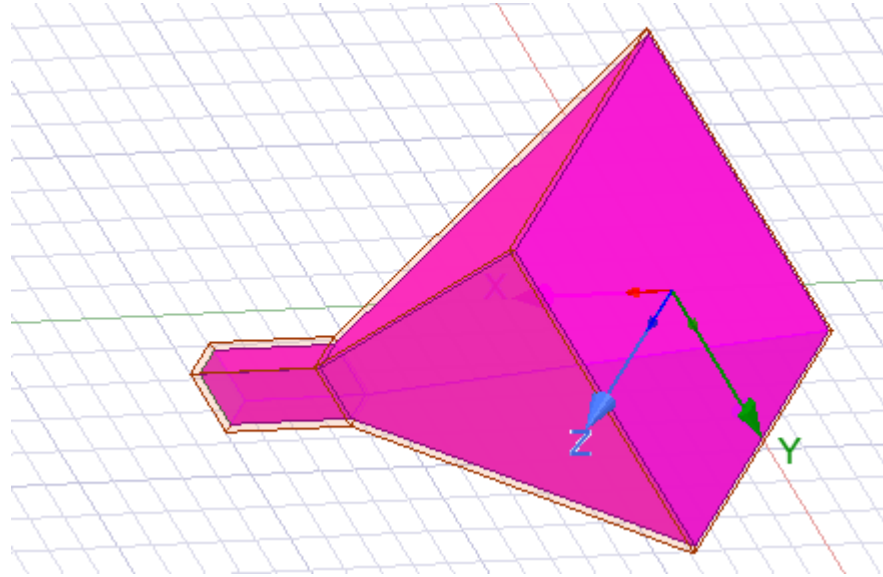

aer

cupru

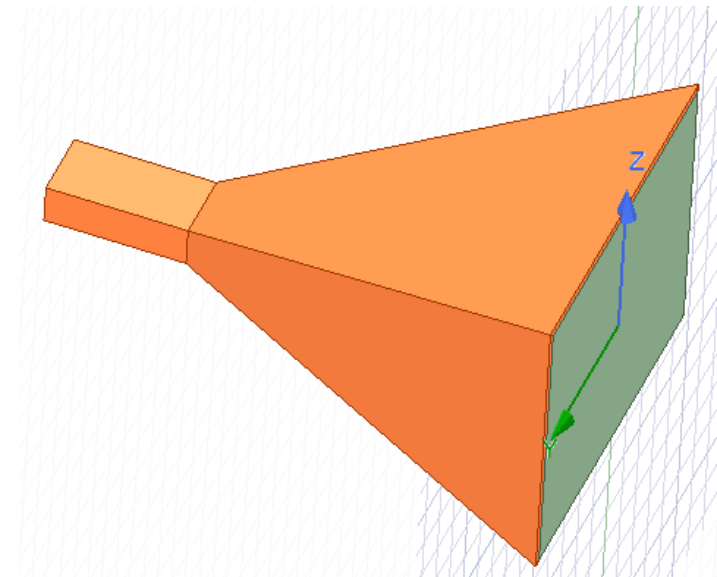
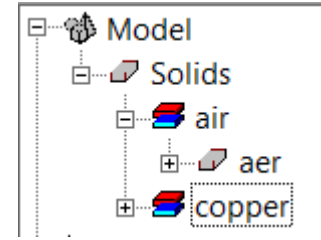

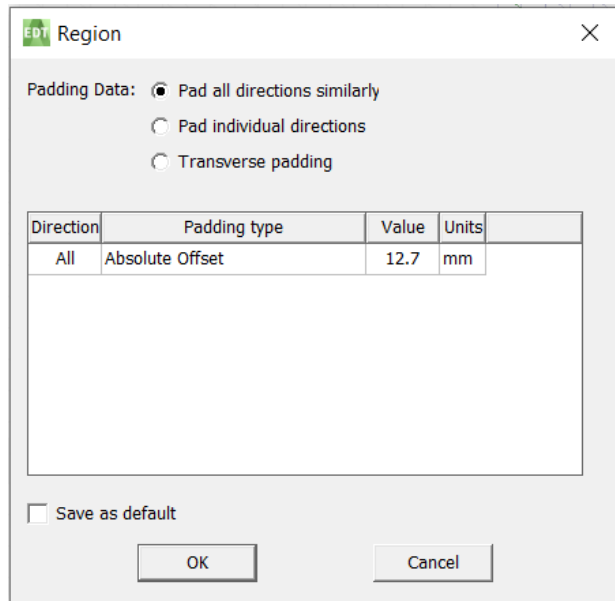

## Crearea unei regiuni

Se va alege optiunea de Absolute Offset, apoi se va introduce valoarea 12.7 mm

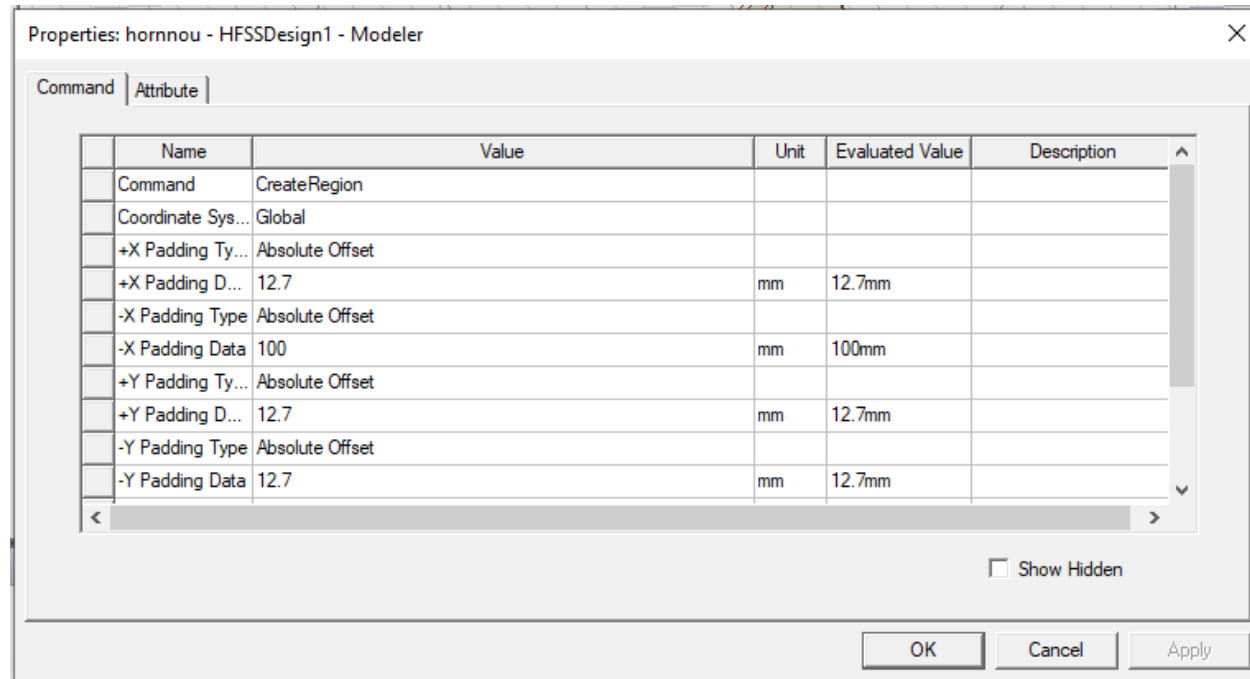

Pentru a modifica ulterior valoarea din fata antenei se va da dublu click pe regiune si modificam la -x Padding Data valoarea la 100 mm

# Implementarea antenei de tip horn

## Desenarea unui dreptunghi care va servi ca port

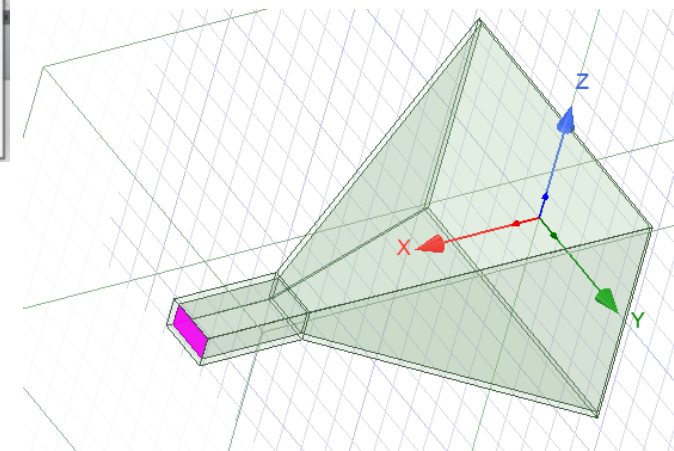
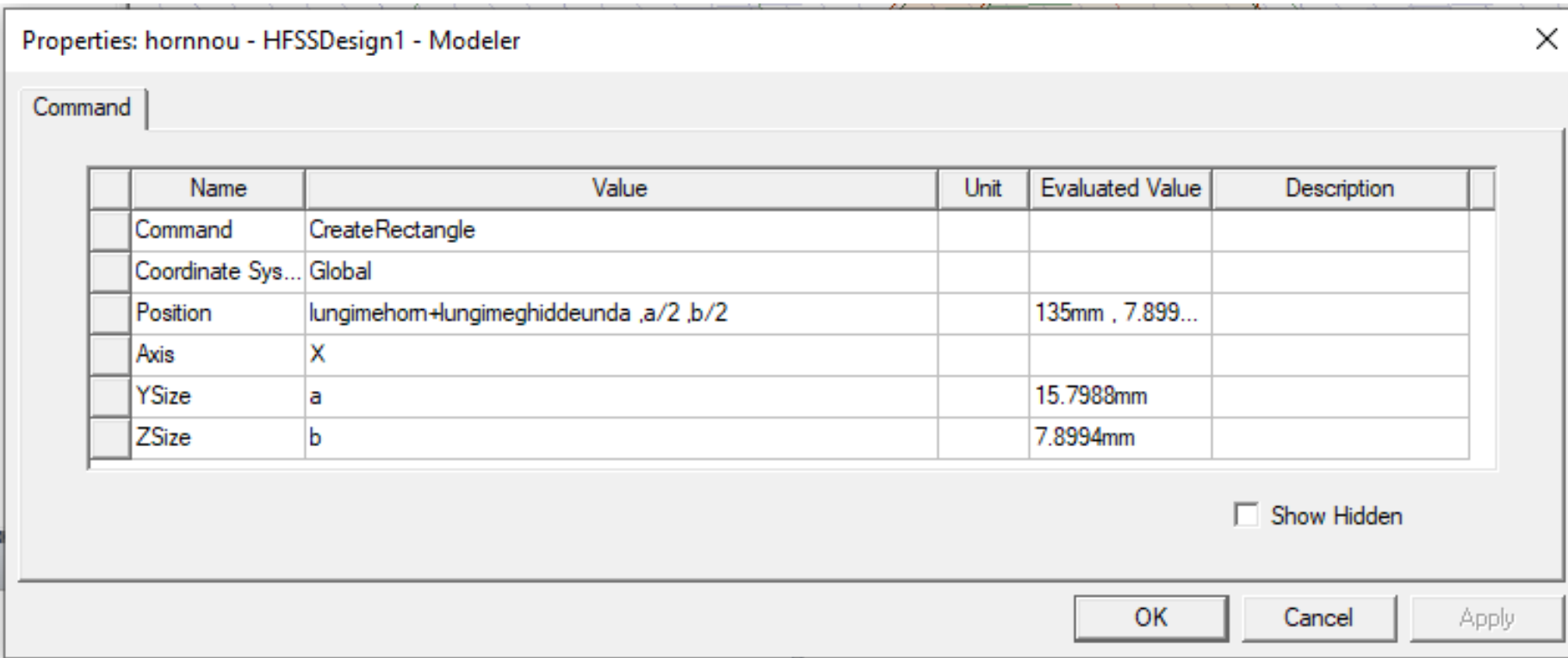
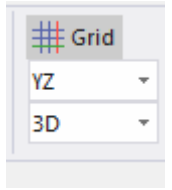

# Atribuirea surselor și a condițiilor de frontieră

- Se va selecta o condiție de frontieră de tip Radiation pe regiunea definită  
Assign Boundary -> Radiation

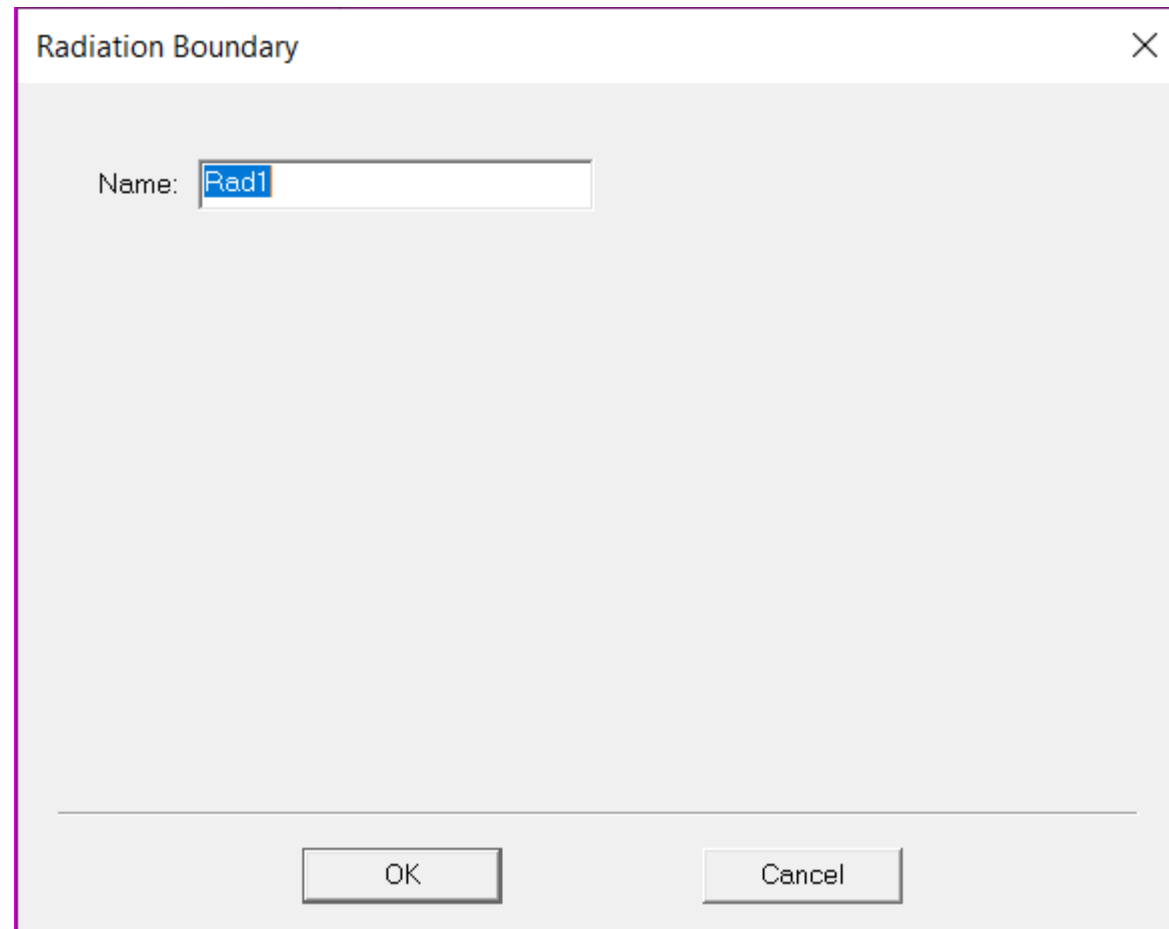

# Atribuirea surselor și a condițiilor de frontieră

- Se va selecta acel dreptunghi pe care l-am desenat anterior și se va apela Assign Excitation ->Waveport...dam next peste tot

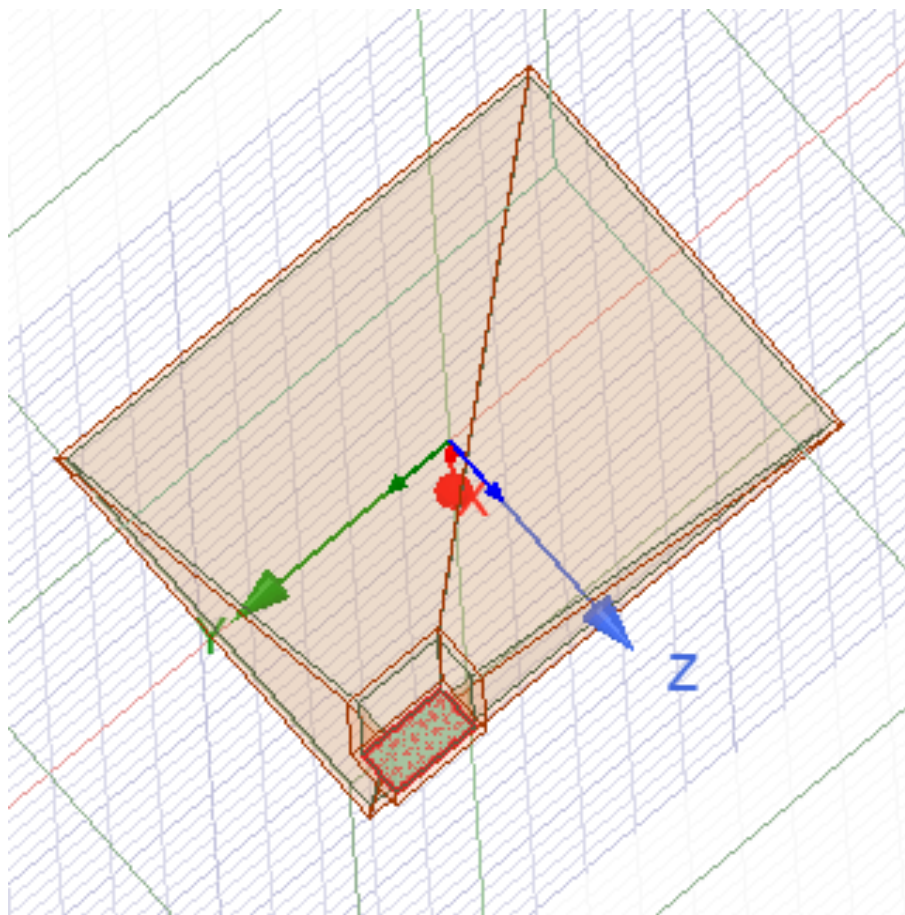

Wave Port : General

Name:

Number of Modes:

Mode	Integration Line	Characteristic Impedance (Zo)
1	None	Zpi

Mode Alignment and Polarity:

Set mode polarity using integration lines

Align modes using integration lines

Align modes analytically using coordinate system

U Axis Line:   Reverse V Direction

Filter modes for reporter

# Setarea parametrilor care se doresc a fi determinați în cadrul lucrării

- Se vor impune setările de rulare/rezolvare/soluționare

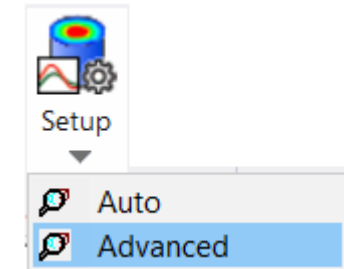
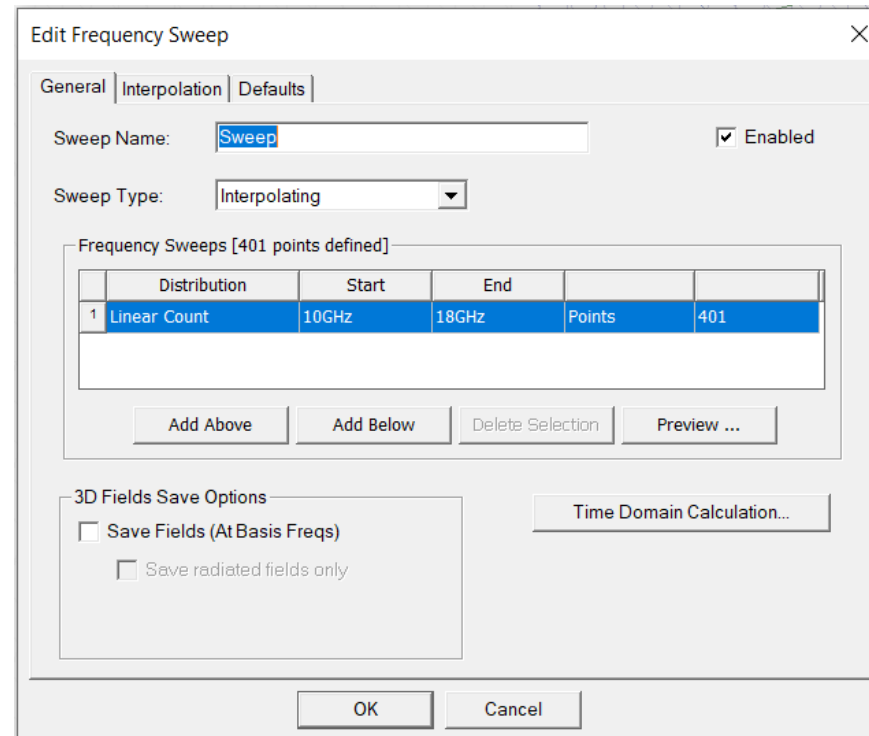
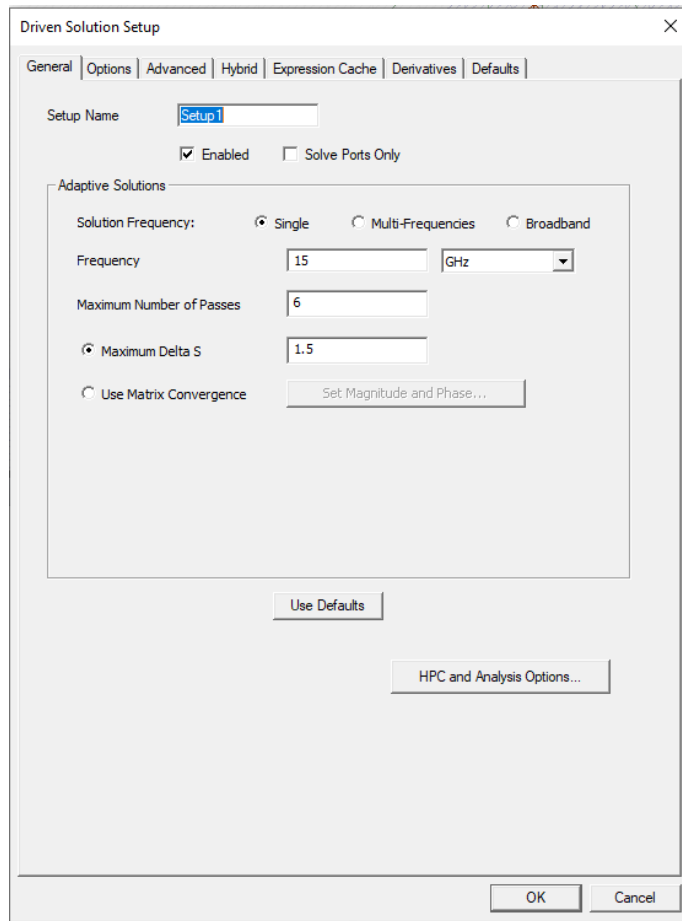

- Se vor rula numeric problema modelată

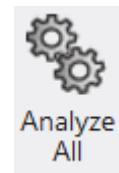
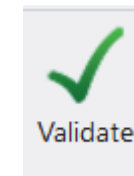
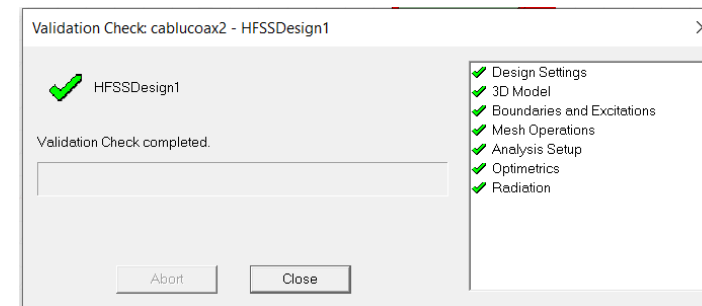

# Setarea parametrilor care se doresc a fi determinați în cadrul lucrării Crearea unei sfere de radiație

Far Field Radiation Sphere Setup

Infinite Sphere | Coordinate System | Radiation Surface

Name: Infinite Sphere1

Phi

Start: 0 deg

Stop: 36 deg

Step Size: 2 deg

Theta

Start: 0 deg

Stop: 180 deg

Step Size: 2 deg

Save As Defaults View Sweep Points...

OK Cancel Help

# Culegerea, interpretarea și postprocesarea rezultatelor

Solutions: horn piramidal - HFSSDesign1

Simulation: Setup1

Design Variation: 'imm' deschidereb='72mm' grosimeperete='1.27mm' lungimeghiddeunda='35mm' lungimehorn='100mm'

Profile | **Convergence** | Matrix Data | Mesh Statistics

Number of Passes

Completed	2
Maximum	6
Minimum	1

Max Mag. Delta S

Target	1.5
Current	0.030583

View:  Table  Plot

Export...

**CONVERGED**

Consecutive Passes

Target	1
Current	1

Default Settings

Save Defaults Clear Defaults

Pass Number	Solved Elements	Max Mag. Delta S
1	75890	N/A
2	87172	0.030583

Close

Solutions: horn piramidal - HFSSDesign1

Simulation: Setup1

Design Variation: 'imm' deschidereb='72mm' grosimeperete='1.27mm' lungimeghiddeunda='35mm' lungimehorn='100mm'

Profile | **Convergence** | Matrix Data | Mesh Statistics

Total number of elements: 91043

	Num Tets	Min edge length	Max edge length	RMS edge length	Min tet vol	Max tet vol	Mean tet vol	Std Devn (vol)
aer	15906	1.39643	11.4312	6.98417	0.0788788	83.2265	16.5303	11.155
horn	3871	1.97485	17.1605	8.10098	0.00798886	20.2614	7.4252	3.62575
Region	71266	4.69625	12.3555	9.03681	0.0205504	121.785	38.1065	14.4776

Export...

Close

# Culegerea, interpretarea și postprocesarea rezultatelor

## Reprezentarea parametrilor S

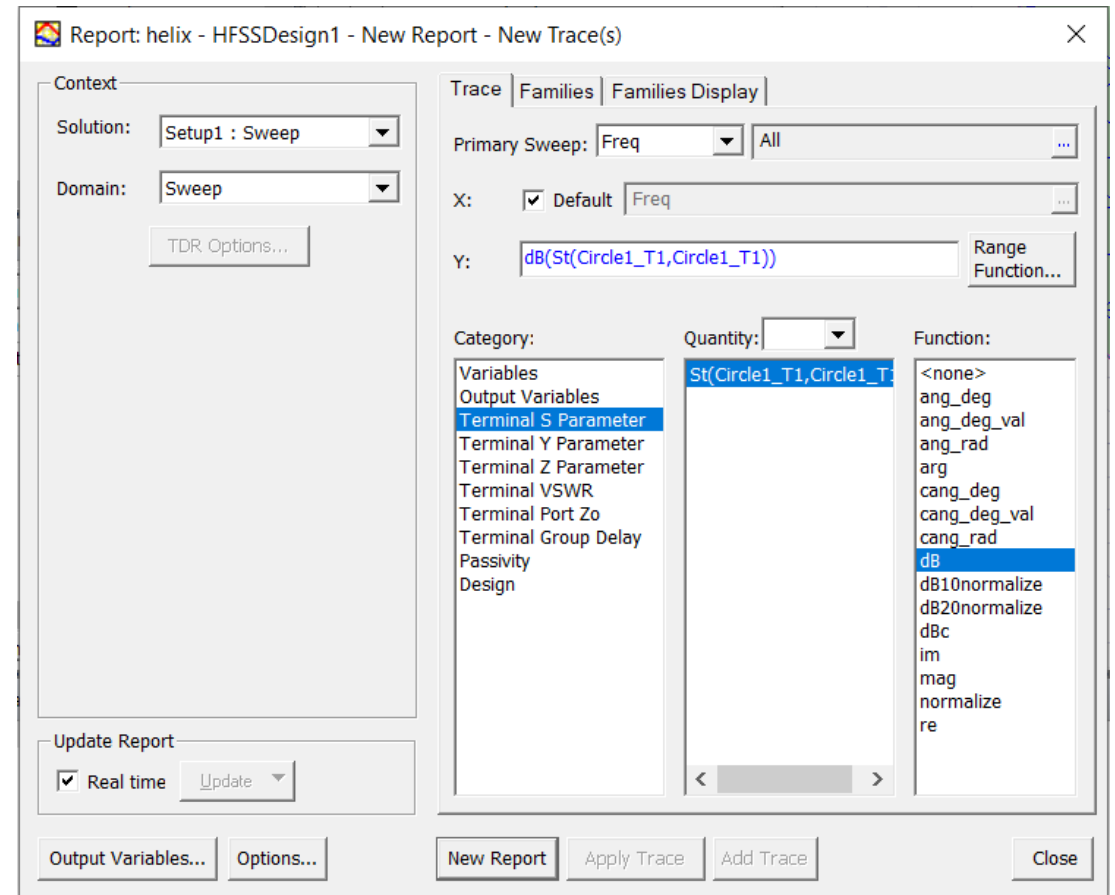
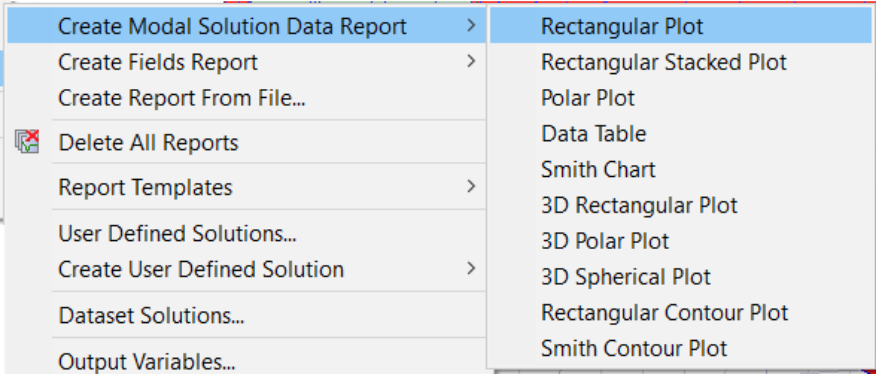
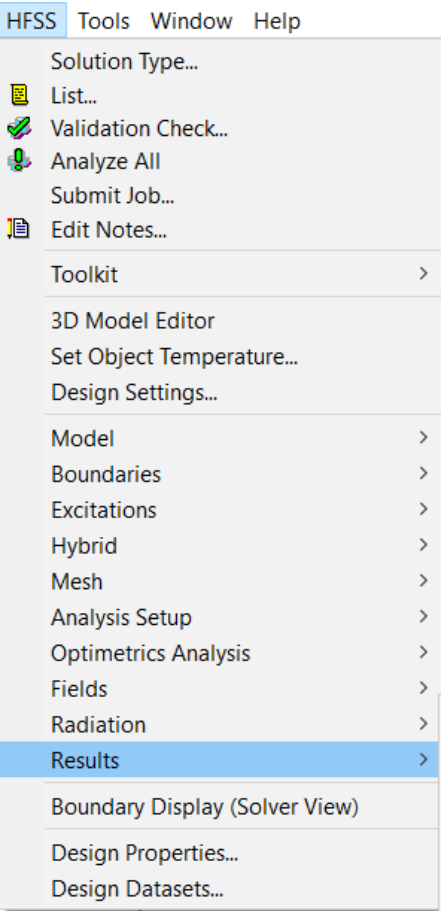

# Culegerea, interpretarea și postprocesarea rezultatelor Reprezentarea parametrilor S

S Parameter Plot 1

HFSSDesign1 ANSYS

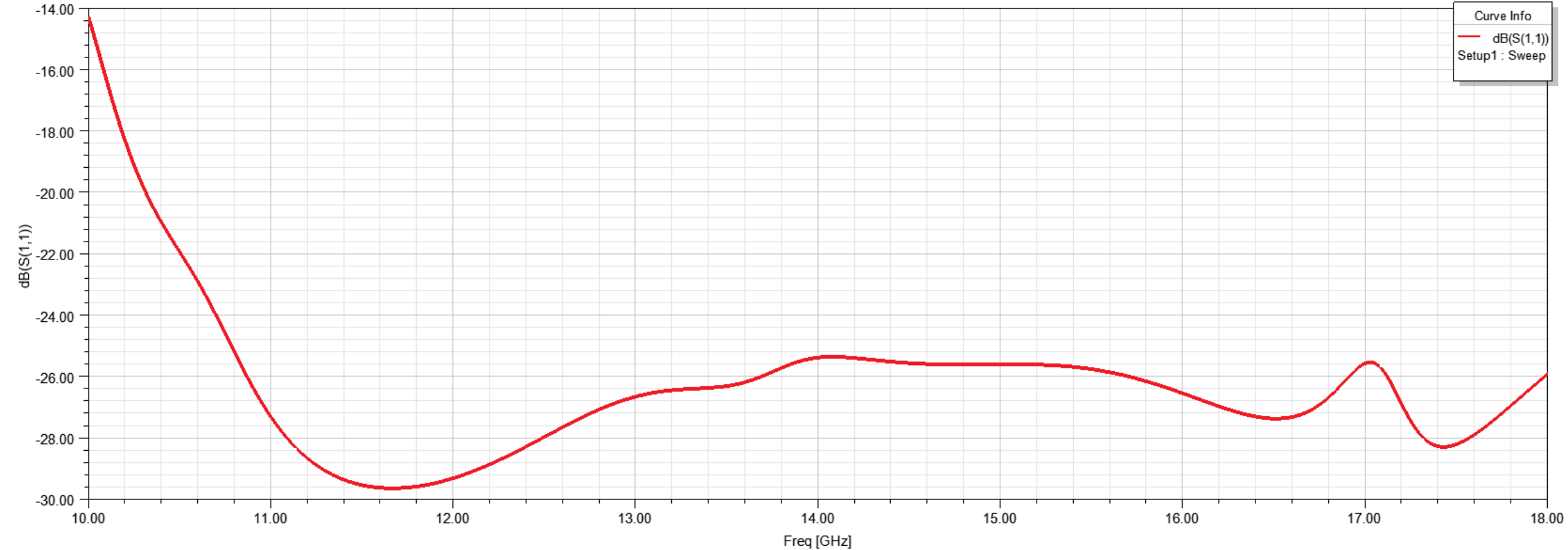

În ce domeniu funcționează antena?

# Culegerea, interpretarea și postprocesarea rezultatelor Reprezentarea radiației

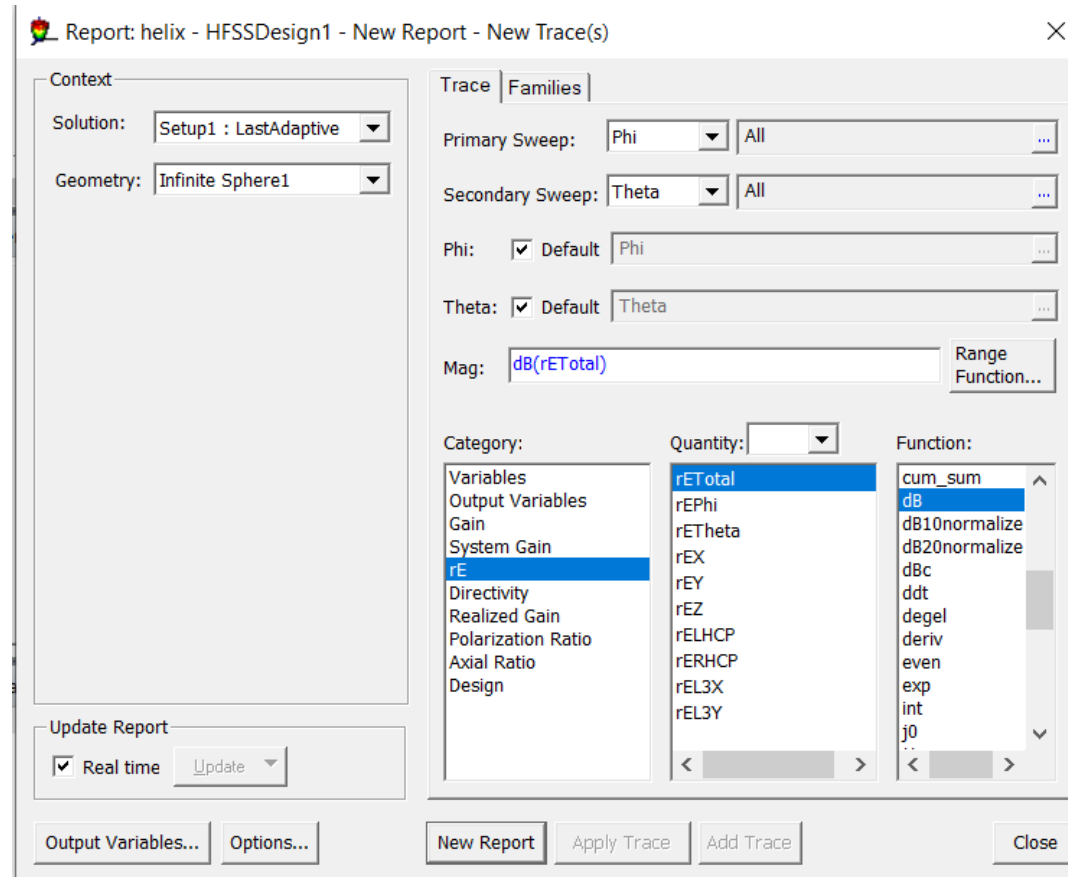
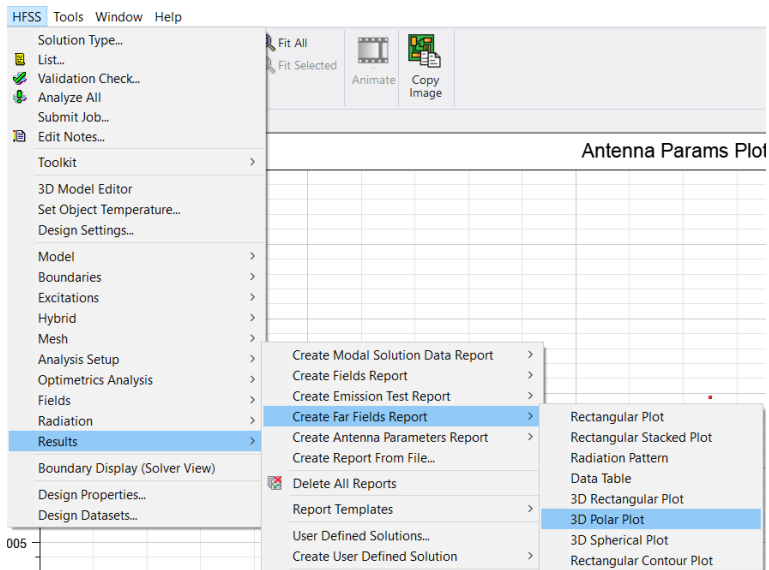

# Culegerea, interpretarea și postprocesarea rezultatelor

## Reprezentarea radiației (rE)

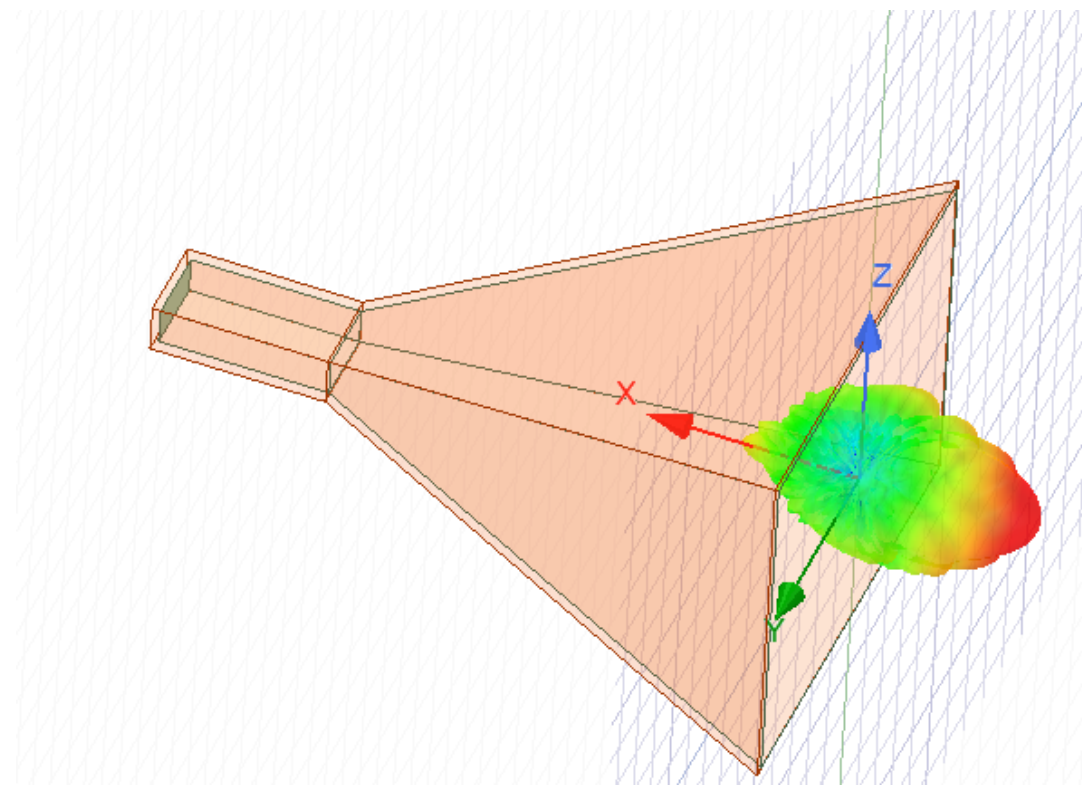
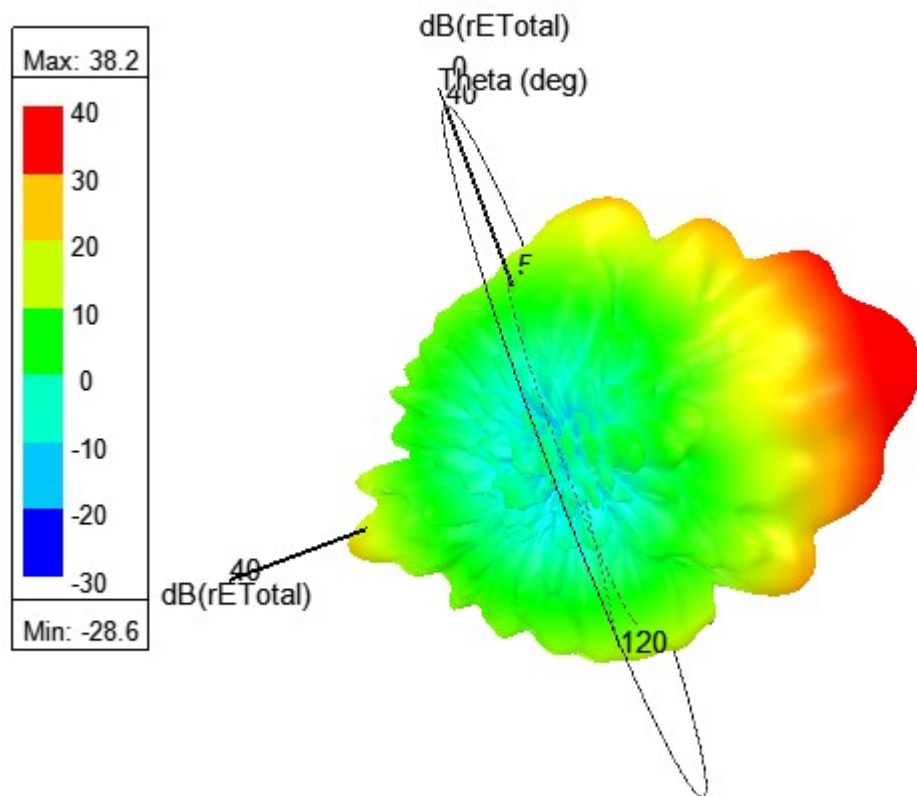

Realizați reprezentarea când apare și antena  
Reprezentați și directivitatea

# Culegerea, interpretarea și postprocesarea rezultatelor

## Reprezentarea câștigului

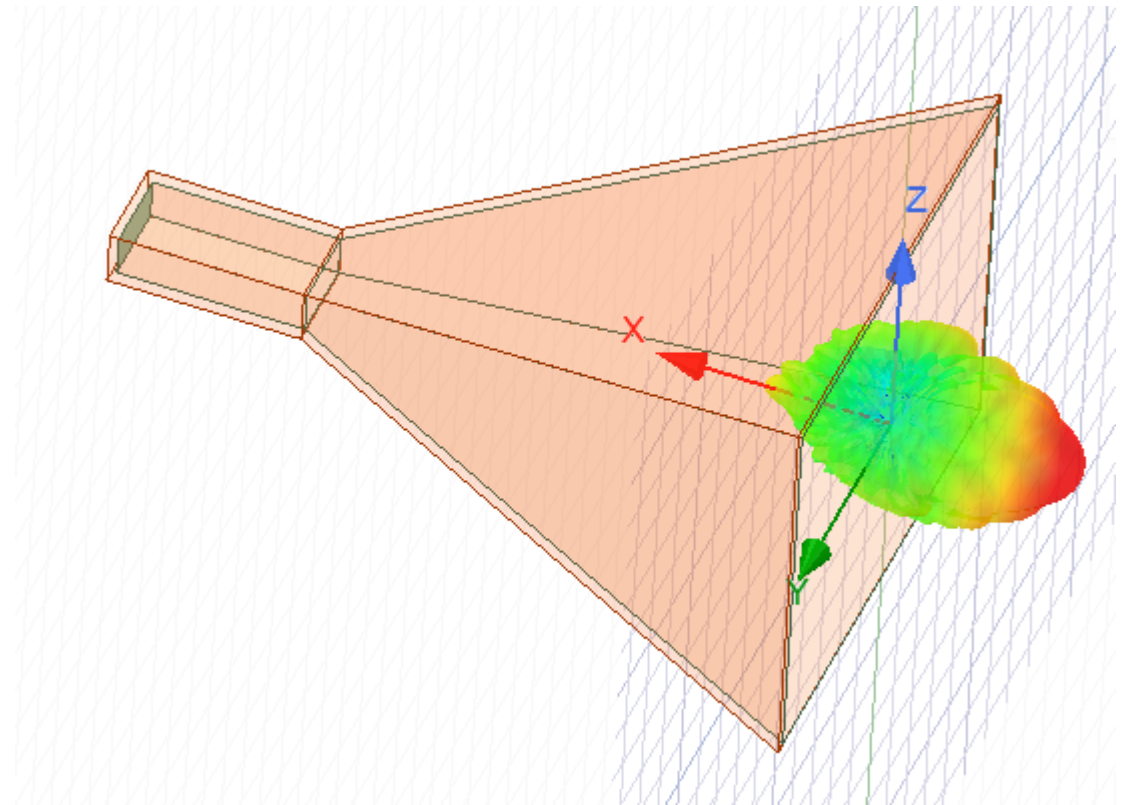
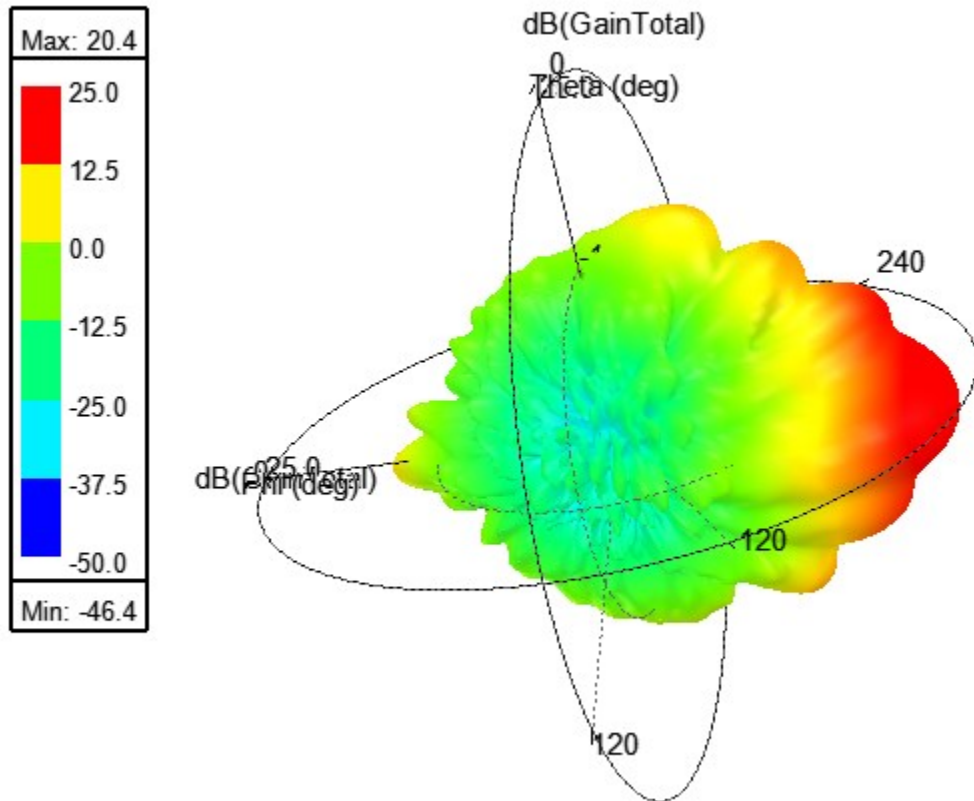

Realizați reprezentarea când apare și antena  
Reprezentați și câștigul și directivitatea

# Culegerea, interpretarea și postprocesarea rezultatelor

## Reprezentarea castigului 2D

- Results->Create Far Field Report->Rectangular Plot

Report: horn piramidal - HFSSDesign1 - New Report - New Trace(s)

Context

Solution: Setup1 : LastAdaptive

Geometry: Infinite Sphere1

Trace Families Families Display

Primary Sweep: Theta All

X:  Default Theta

Y: dB(GainTotal) Range Function...

Category: Variables Output Variables Gain System Gain rE Directivity Realized Gain Polarization Ratio Axial Ratio Design

Quantity: GainTotal GainPhi GainTheta GainX GainY GainZ GainLHCP GainRHCP GainL3X GainL3Y

Function: <none> abs acos acosh ang\_deg ang\_deg\_val ang\_rad asin asinh atan atanh cos cosh cum\_integ cum\_sum dB dB10normalize

Update Report

Real time Update

Output Variables... Options... New Report Apply Trace Add Trace Close

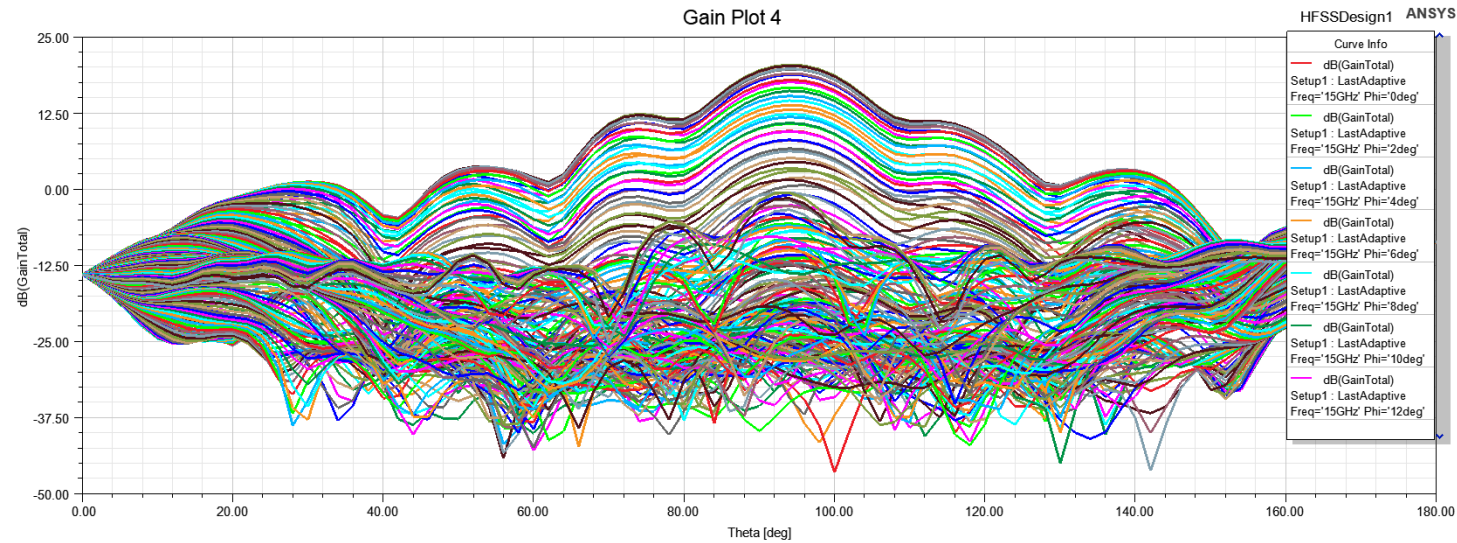

# Culegerea, interpretarea și postprocesarea rezultatelor

## Reprezentarea castigului 2D

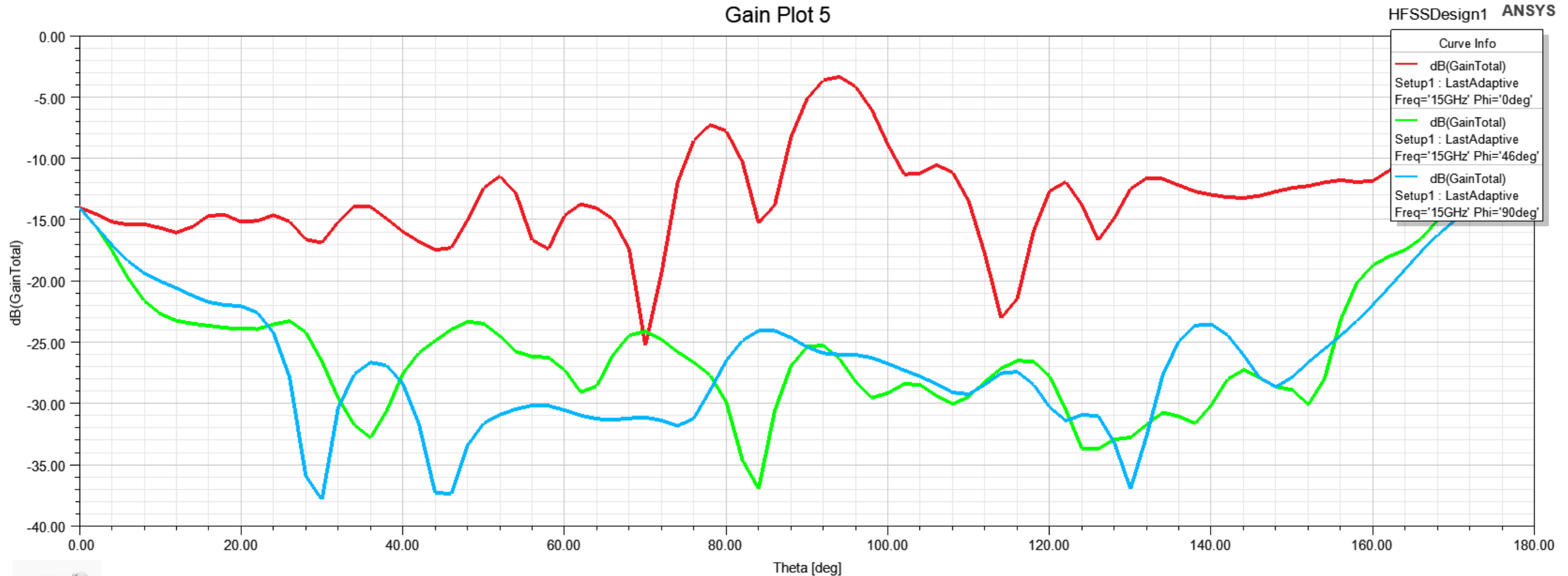

Realizați reprezentarea de mai sus doar pentru  $\phi = 0, 46$  și  $90$ . Care este valoarea maximă a directivității?

# Culegerea, interpretarea și postprocesarea rezultatelor

## Reprezentări distribuția de câmp electric in planul XY

- Alegem planul din Planes, apoi click dreapta pe planul de lucru Plot Fields->E->Mag E

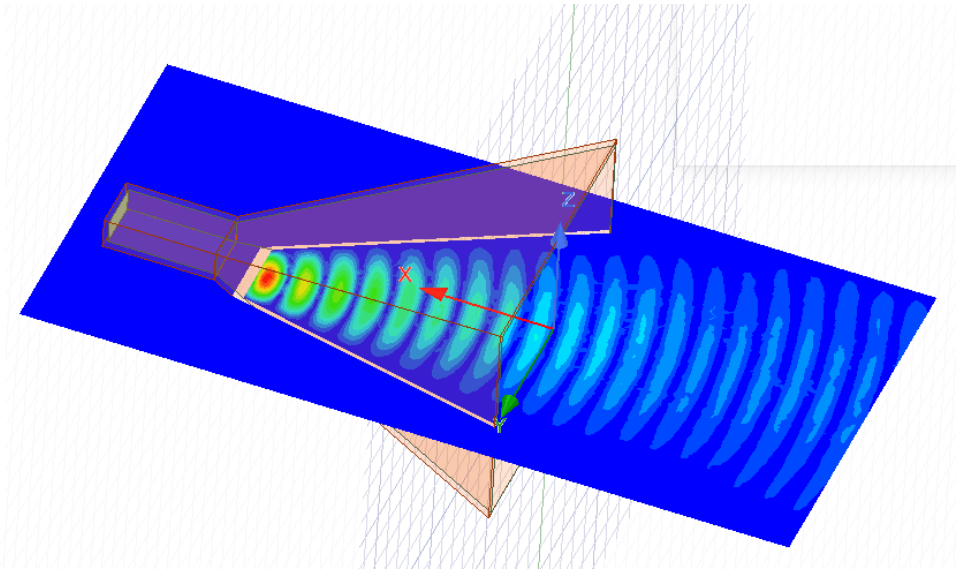
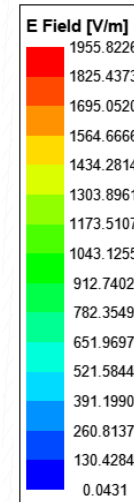
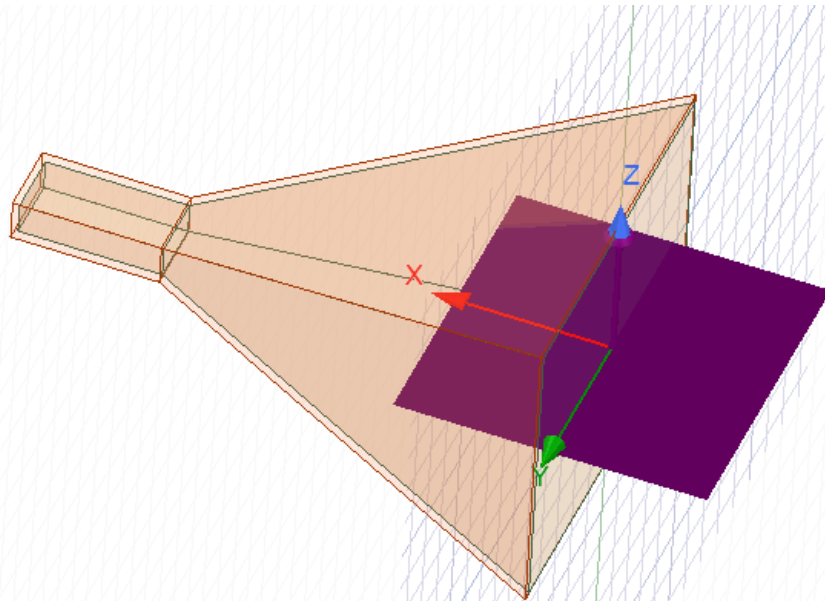

Animati

# Culegerea, interpretarea și postprocesarea rezultatelor

## Reprezentări distribuția de câmp electric în planul XZ

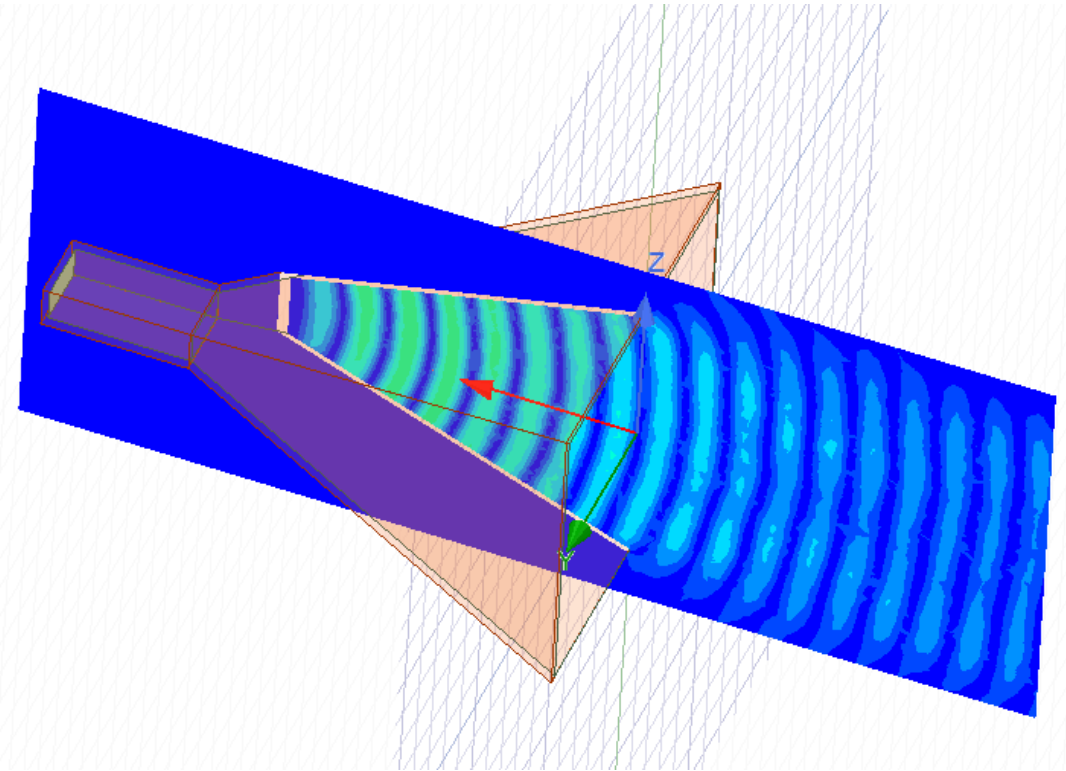
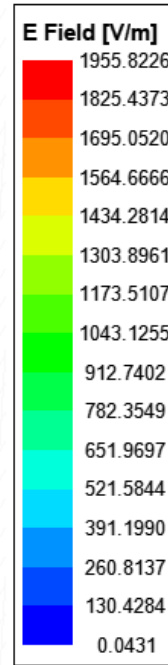
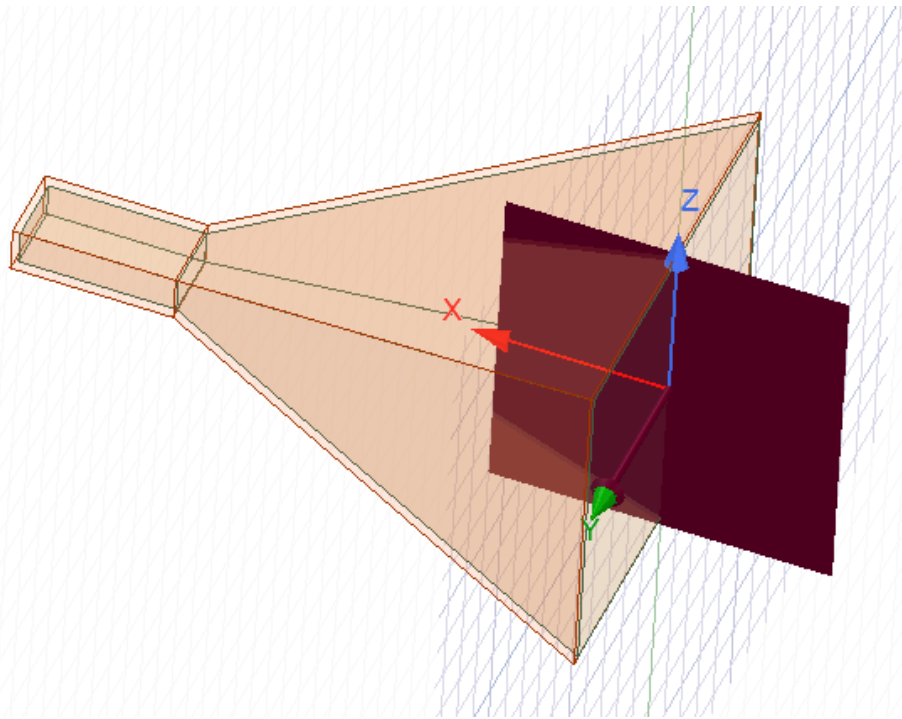

# Culegerea, interpretarea și postprocesarea rezultatelor

## Reprezentări distribuția de câmp magnetic in planul XY

- Alegem planul din Planes, apoi click dreapta pe planul de lucru Plot Fields->E->Mag H

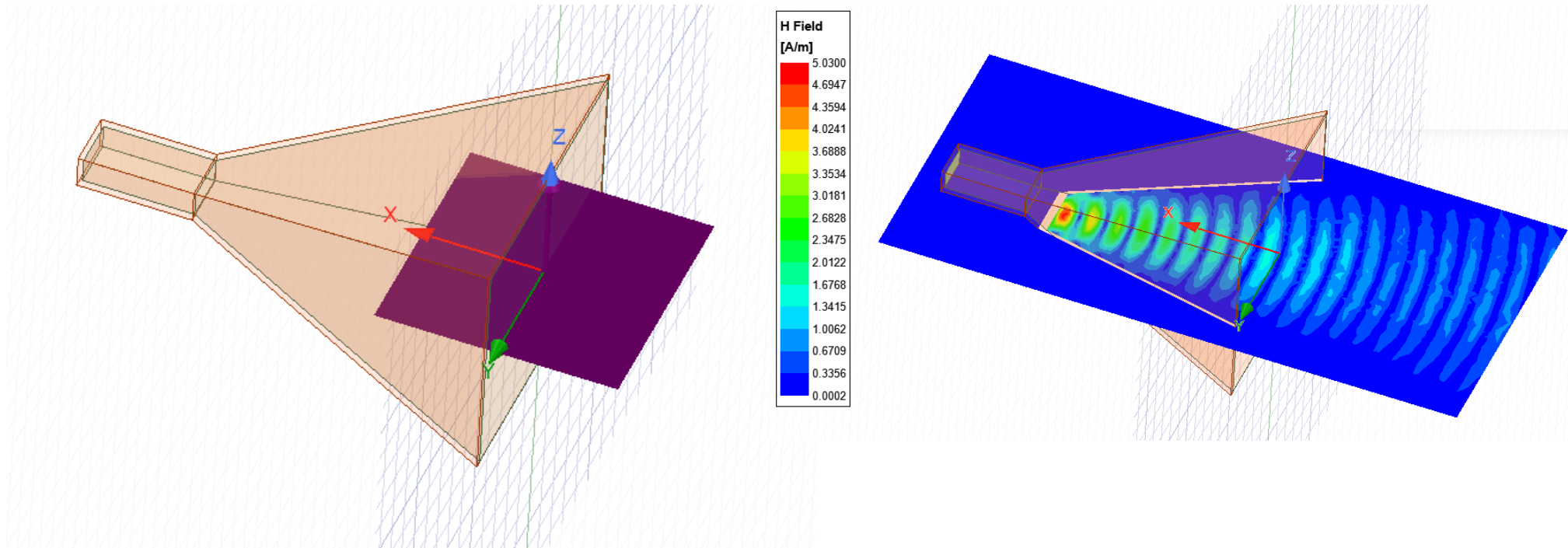

# Culegerea, interpretarea și postprocesarea rezultatelor

## Reprezentări distribuția de câmp magnetic in planul XZ

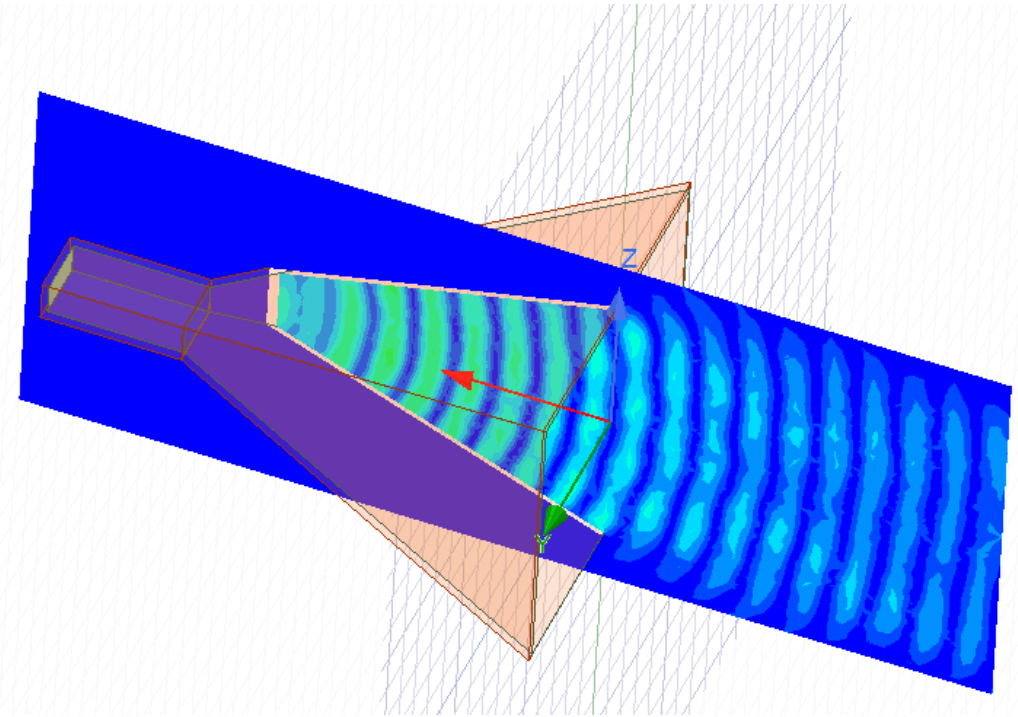
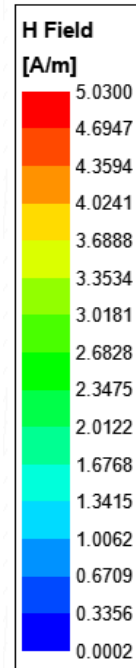
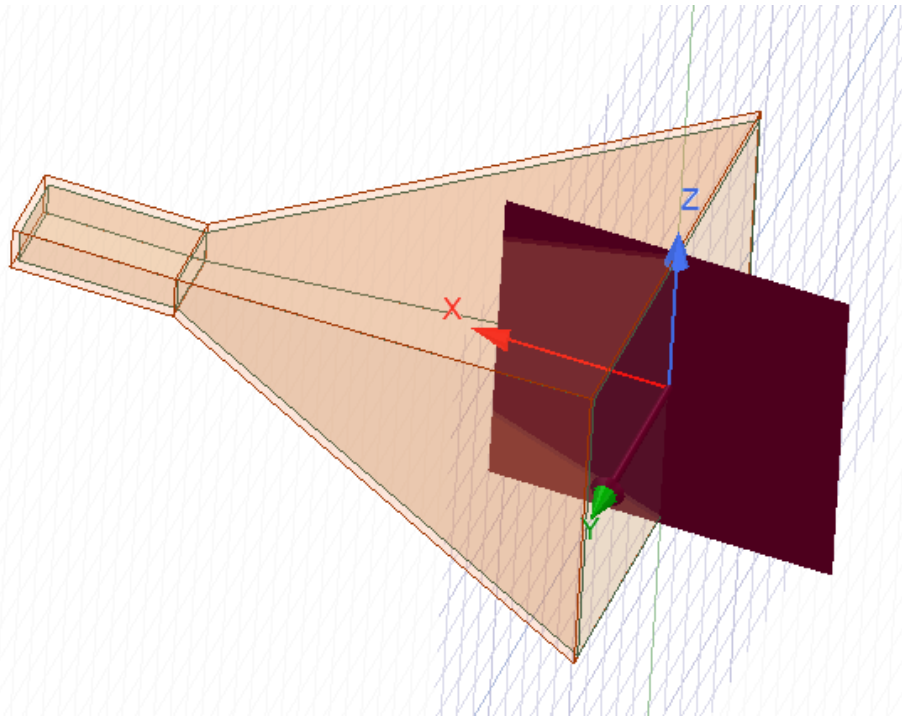

Exista diferente de valori in cele 2 reprezentari pe planuri diferite?



## Aplicații

- Reprezentați VSWR
- Reprezentați și meshul modelului

**Temă** Modificați dimensiunile Hornului astfel încât să obțineți o antenă sectorială de plan H sau de plan E și urmăriți modificările apărute în parametrii de interes

# Antena horn circulara

## Enunțul lucrării

- Să se modeleze și analizeze o antenă de tip horn circulară folosind Ansoft HFSS.

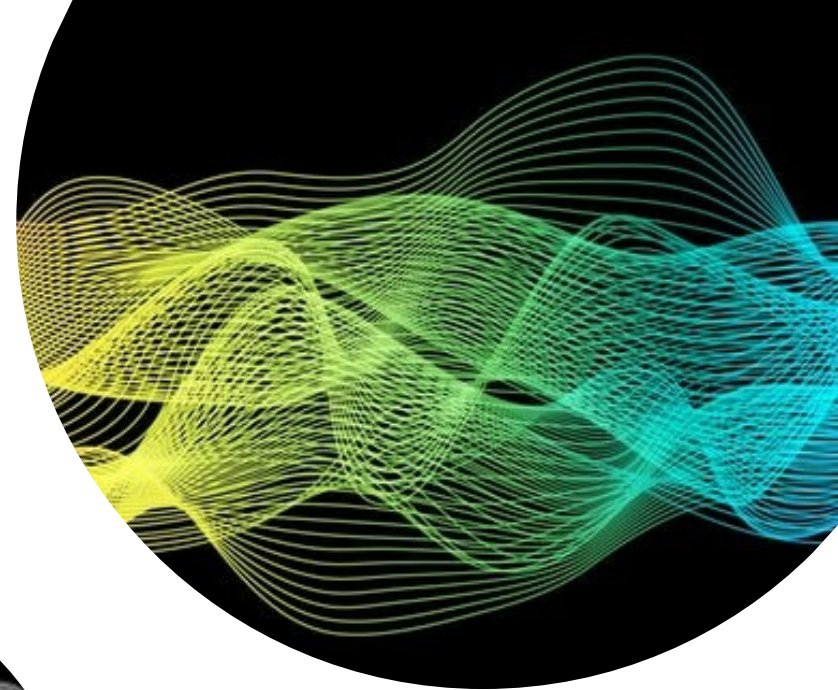

# Enunțul lucrării

<https://manualzz.com/doc/29697004/circular-and-rectangular-horn-antennas>

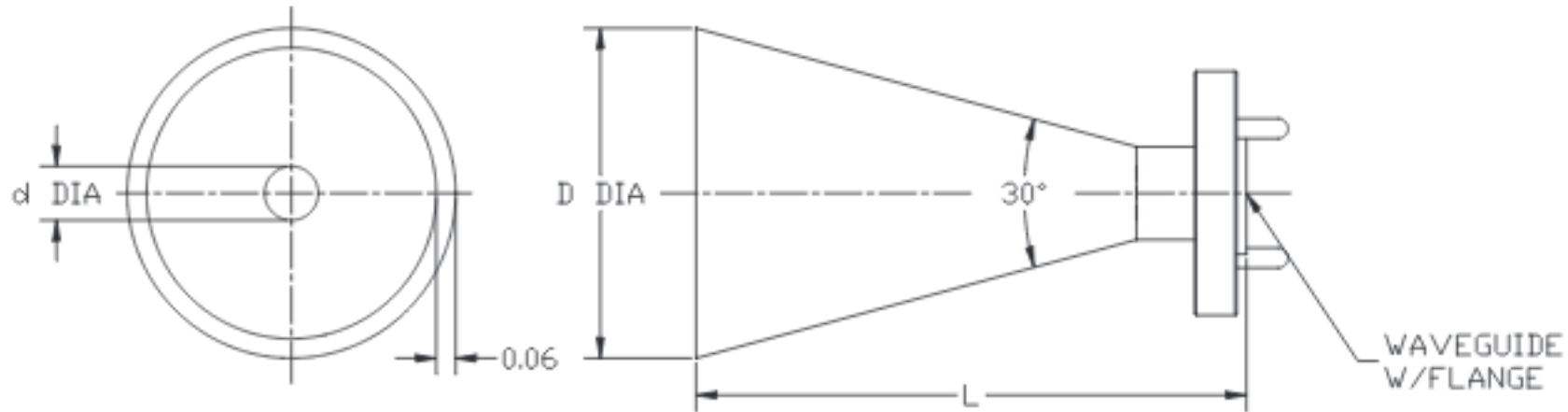

Band	Frequency	Flange	D x d x L			
			Gain=15dB, BW=24°	Gain=20dB, BW=13°	Gain=23dB, BW=9°	Gain=25dB, BW=7°
K	24GHz	UG595/U	1.31 x 0.368 x 2.30	2.36 x 0.368 x 4.40	3.39 x 0.368 x 6.30	4.34 x 0.368 x 8.00
K <sub>a</sub>	35GHz	UG599/U	0.93 x 0.250 x 1.70	1.65 x 0.250 x 3.00	2.36 x 0.250 x 4.30	3.01 x 0.250 x 5.50
Q	42GHz	UG383/U	0.80 x 0.219 x 1.30	1.40 x 0.219 x 2.50	1.99 x 0.219 x 3.60	2.53 x 0.219 x 4.60
U	50GHz	UG383/U-M	0.69 x 0.188 x 1.20	1.19 x 0.188 x 2.10	1.69 x 0.188 x 3.10	2.14 x 0.188 x 3.90
V	60GHz	UG385/U	0.60 x 0.141 x 1.10	1.02 x 0.141 x 1.80	1.43 x 0.141 x 2.60	1.81 x 0.141 x 3.30
E	77GHz	UG387/U	0.49 x 0.125 x 0.90	0.82 x 0.125 x 1.50	1.14 x 0.125 x 2.10	1.43 x 0.125 x 2.70
W	94GHz	UG387/U-M	0.42 x 0.094 x 0.70	0.69 x 0.094 x 1.20	0.96 x 0.094 x 1.80	1.20 x 0.094 x 2.30

<https://www.amtechs.co.jp/maker/b63c7cf9f3aad6acec500872e00f3244310977d7.pdf>

# Obiectivele lucrării

- Modelarea unei antene horn circulare



Determinarea câștigului ca polar plot

Determinarea radiației  $rE$  ca polar plot

Reprezentarea parametrilor  $S$

Determinarea distribuției de câmp electric pe planul  $XY$

Determinarea distribuției de câmp electric pe planul  $YZ$

Determinarea distribuției de câmp magnetic pe planul  $XY$

Determinarea distribuției de câmp magnetic pe planul  $YZ$

Reprezentarea radiației

# Implementarea modelului pentru modelare numerică

- Se deschide Ansys Electronics Desktop
- Se va alege să se modeleze un proiect HFSS

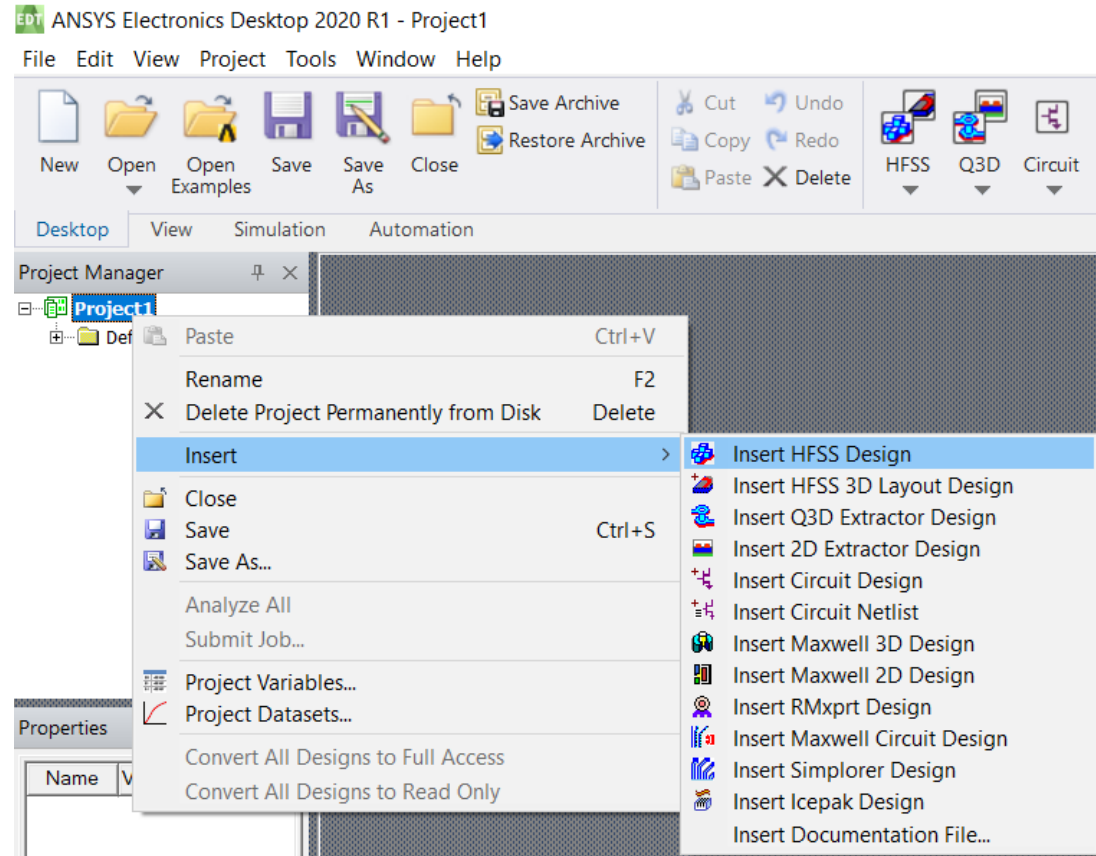
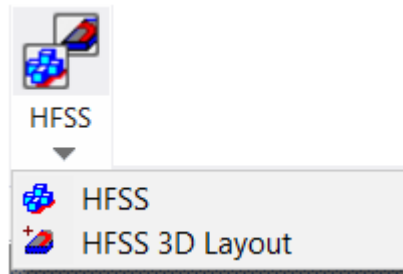

# Implementarea modelului pentru modelare numerică

- Vom alege unitatea de măsură pentru model din Modeler ->Units...

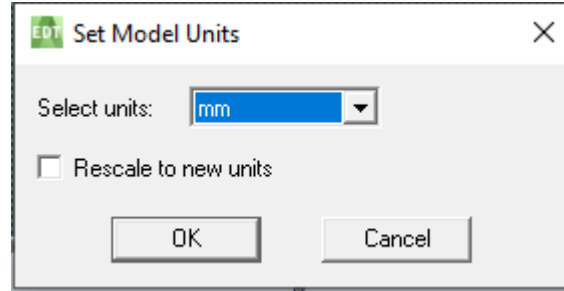

- Vom alege tipul soluției din HFSS->Solution Type

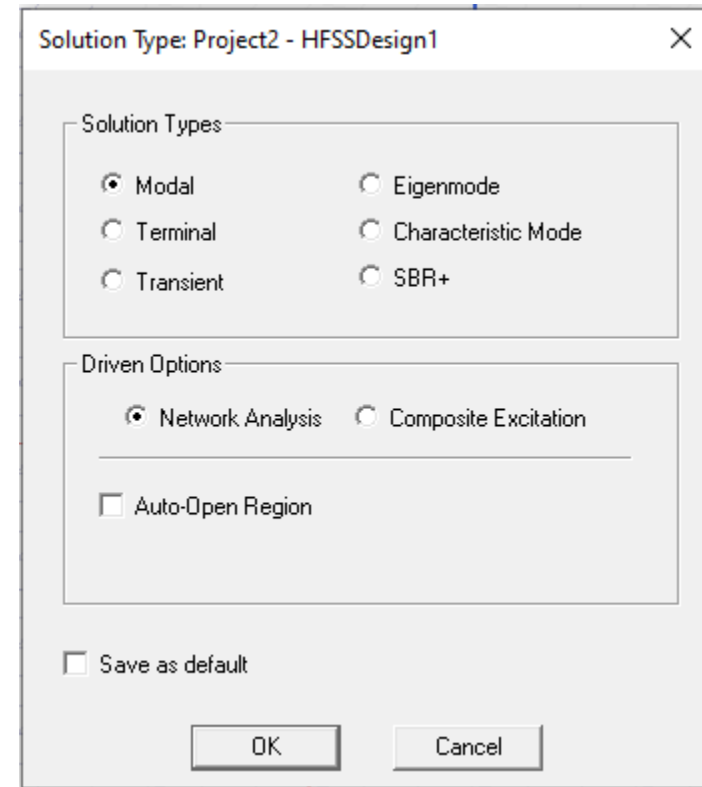

# Implementarea antenei de tip horn

## Desenarea ghidului de undă

- Vom orienta planul de lucru in urmatorul mod
  - Desenăm o linie si profitam de posibilitatea de a crea o geometrie bazata pe simetrie, astfel alegem Draw->Line
  - Vpm crea o linie cu primul punct in 0, apoi inca 3 puncte ca in imagine

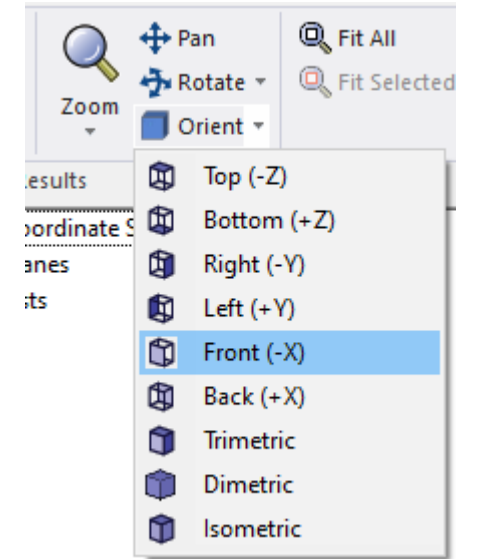
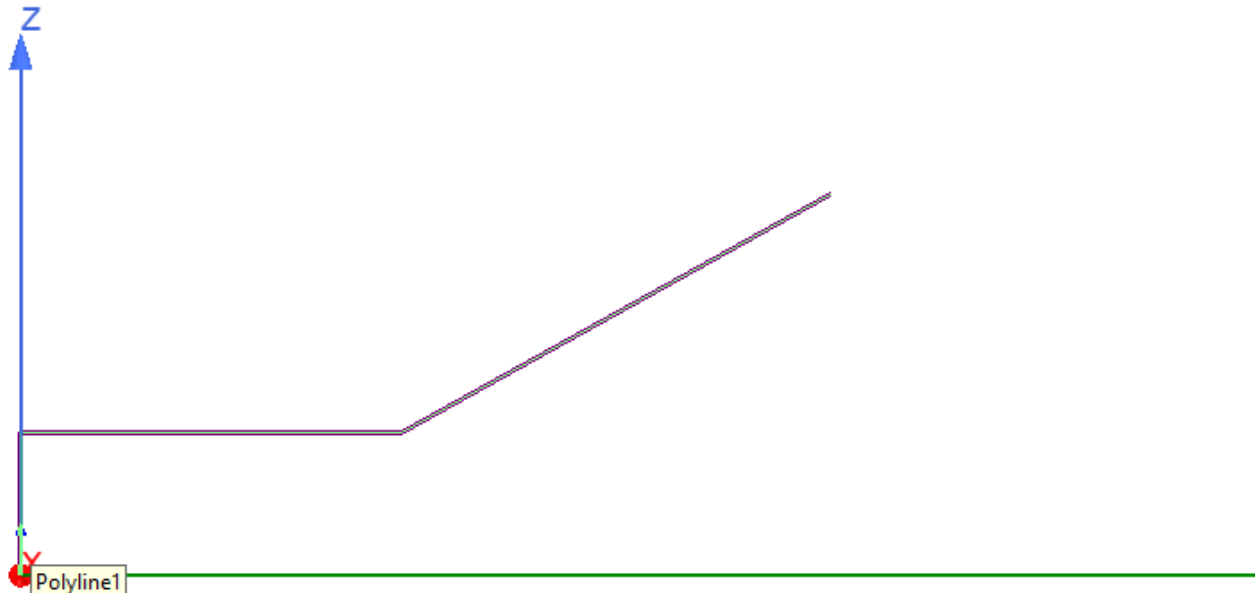

# Implementarea antenei de tip horn

## Desenarea ghidului de undă

Name	Value	Unit	Evaluated Value
Segment ...	Line		
Point1	0 ,0 ,0	mm	0mm , 0mm , 0mm
Point2	0 ,0 ,4.6736	mm	0mm , 0mm , 4...

Name	Value	Unit	Evaluated Value
Segment ...	Line		
Point1	0 ,0 ,4.6736	mm	0mm , 0mm , 4...
Point2	0 ,15 ,4.6736	mm	0mm , 15mm , 4...

Name	Value	Unit	Evaluated Value
Segment ...	Line		
Point1	0 ,15 ,4.6736	mm	0mm , 15mm , 4...
Point2	0 ,58.42 ,16.637	mm	0mm , 58.42mm...

- Urmatorul pas va fi selectarea polyline-ului si crearea obiectului din el cu ajutorul comenzii Draw-> sweep around axis sau cu click pe 

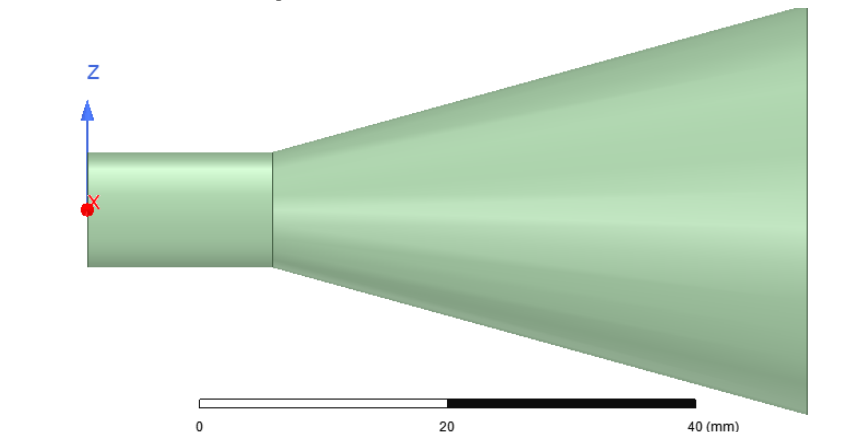
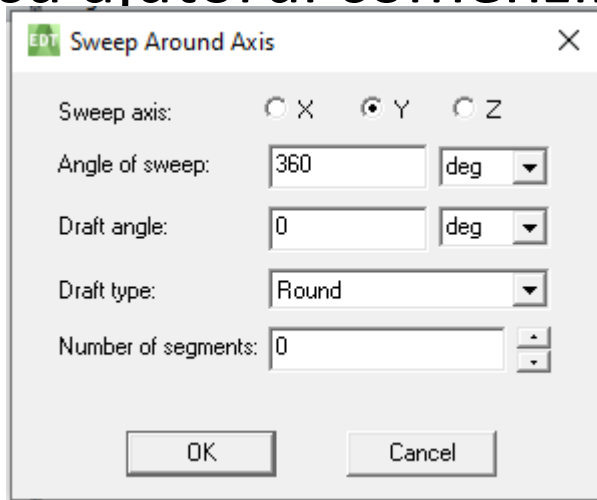

# Implementarea antenei de tip horn

## Desenarea ghidului de undă

- Vom face peretele de conductor mai gros selectand geometria si din Modeler->Surface->Thicken Sheet... ii dam o grosime de 1.524 mm

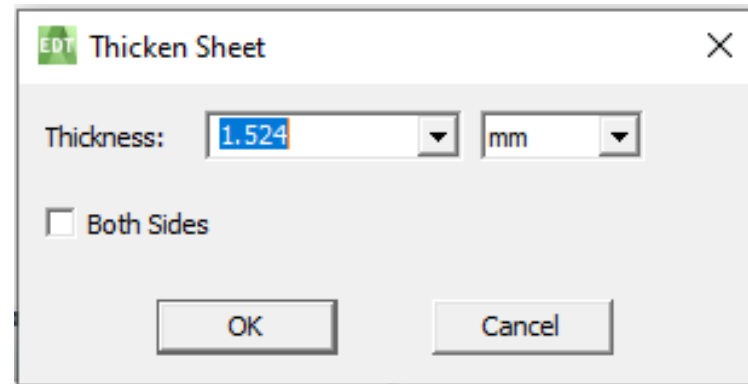

- Materialul ales pentru structura va fi aluminiu ; structura va fi numita horn si va avea culoarea gri

# Implementarea antenei de tip horn

## Desenarea unui cerc ce va servi ca port

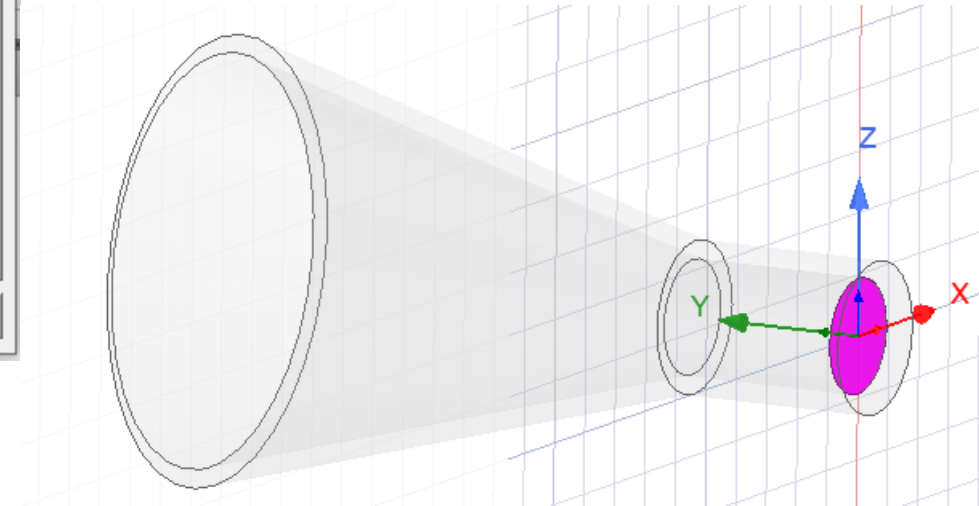
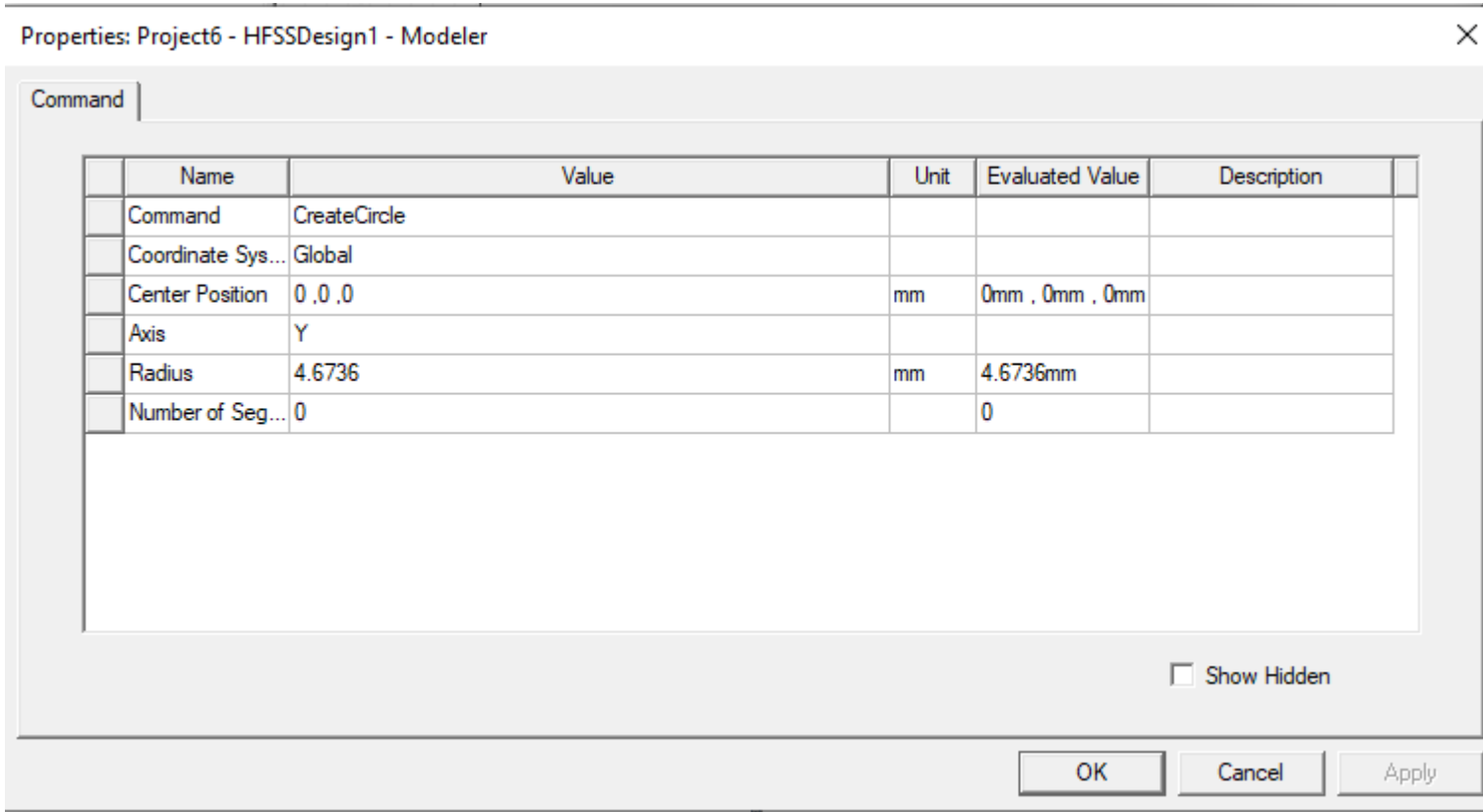
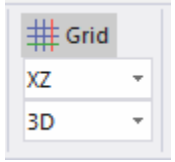

# Atribuirea surselor și a condițiilor de frontieră

- Se va selecta o condiție de frontieră de tip Radiation pe regiunea definită Assign Boundary -> Radiation pe regiune

EDT Region

Padding Data:  Pad all directions similarly  
 Pad individual directions  
 Transverse padding

Direction	Padding type	Value	Units
All	Percentage Offset	20	

Save as default

OK Cancel

Radiation Boundary

Name: Rad1

OK Cancel

## Atribuirea surselor și a condițiilor de frontieră

- Se va selecta acel cerc pe care l-am desenat anterior și se va apela Assign Excitation ->Waveport...dam next peste tot

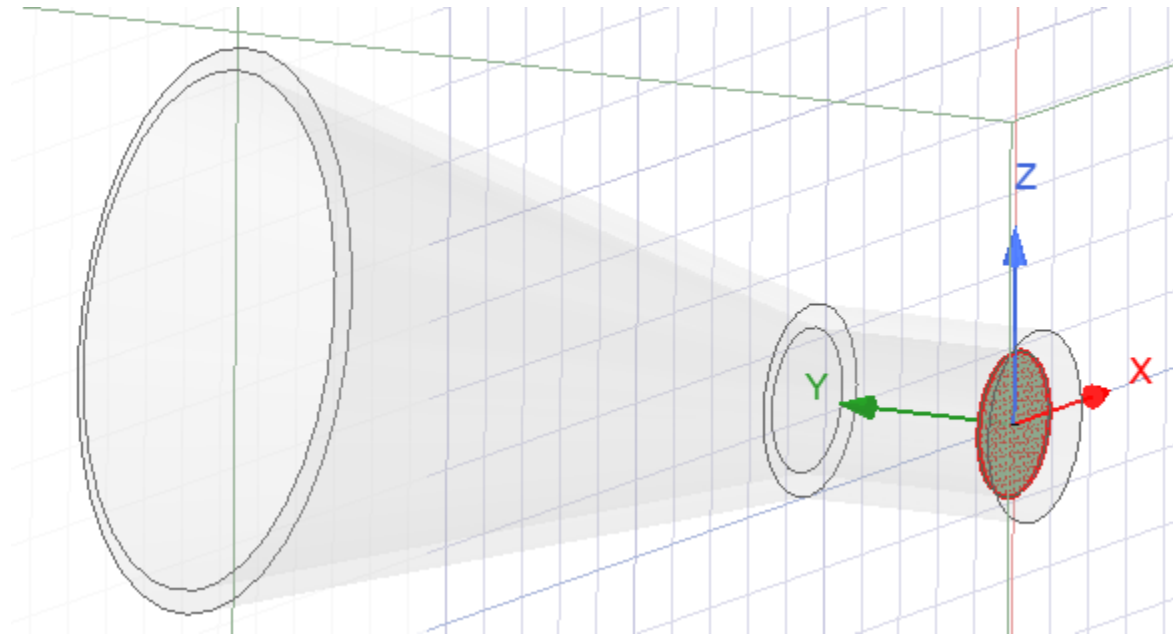

# Setarea parametrilor care se doresc a fi determinați în cadrul lucrării

- Se vor impune setările de rulare/rezolvare/soluționare

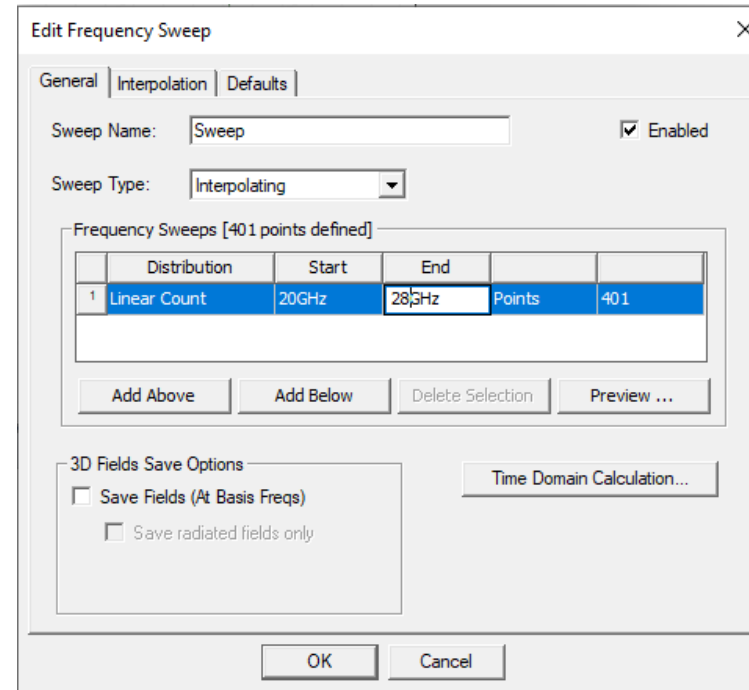
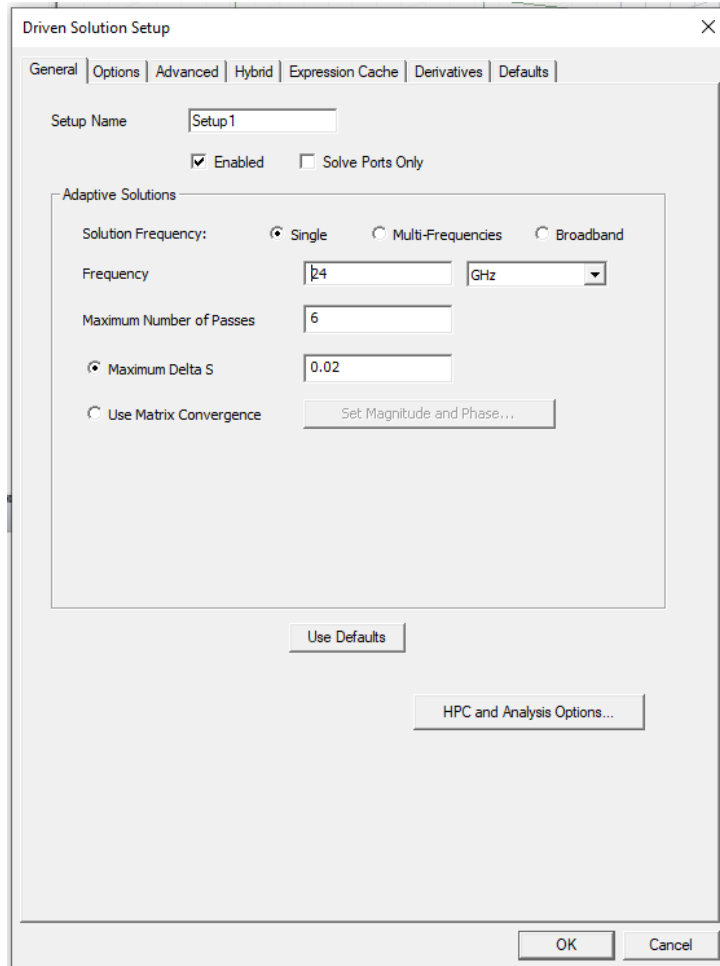

- Se vor rula numeric problema modelată

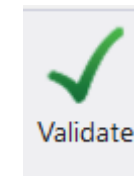
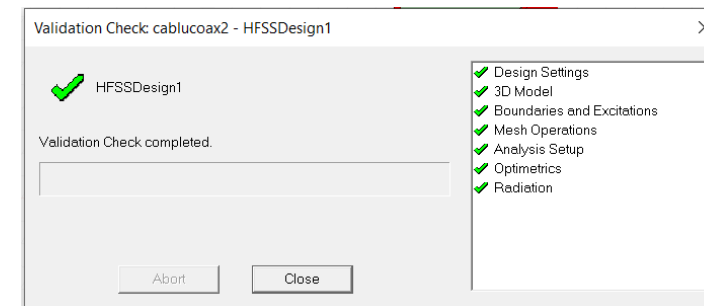

# Setarea parametrilor care se doresc a fi determinați în cadrul lucrării Crearea unei sfere de radiație

Far Field Radiation Sphere Setup

Infinite Sphere | Coordinate System | Radiation Surface

Name: Infinite Sphere1

Phi

Start: 0 deg

Stop: 360 deg

Step Size: 10 deg

Theta

Start: 0 deg

Stop: 180 deg

Step Size: 10 deg

Save As Defaults View Sweep Points...

OK Cancel Help

# Culegerea, interpretarea și postprocesarea rezultatelor

## Reprezentarea parametrilor S

S Parameter Plot 1

HFSSDesign1 ANSYS

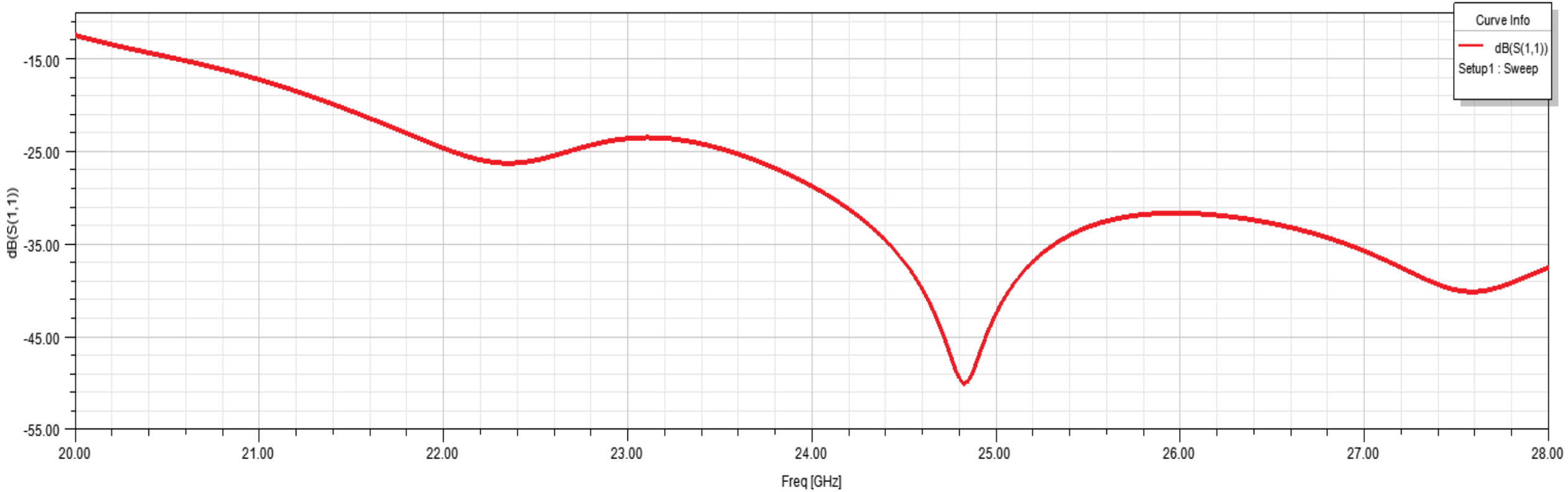

# Culegerea, interpretarea și postprocesarea rezultatelor

## Reprezentarea castigului

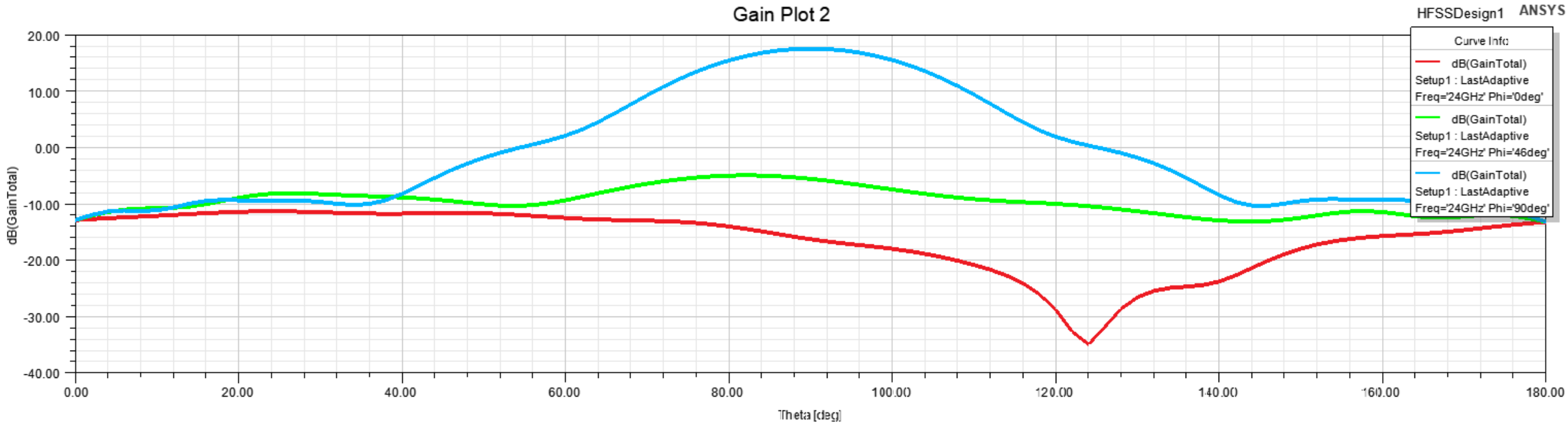

Gain Plot 3

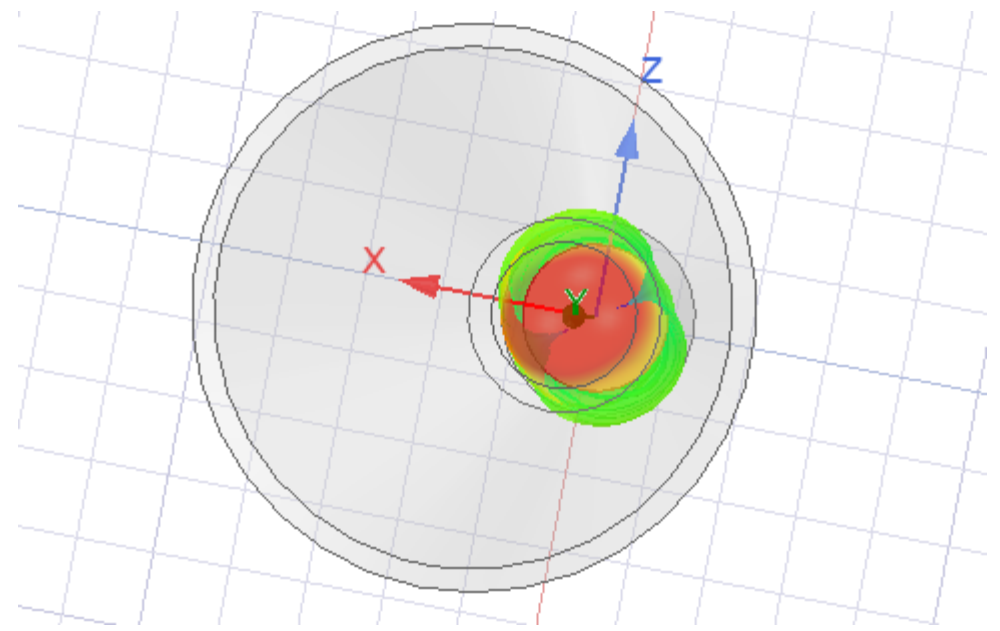
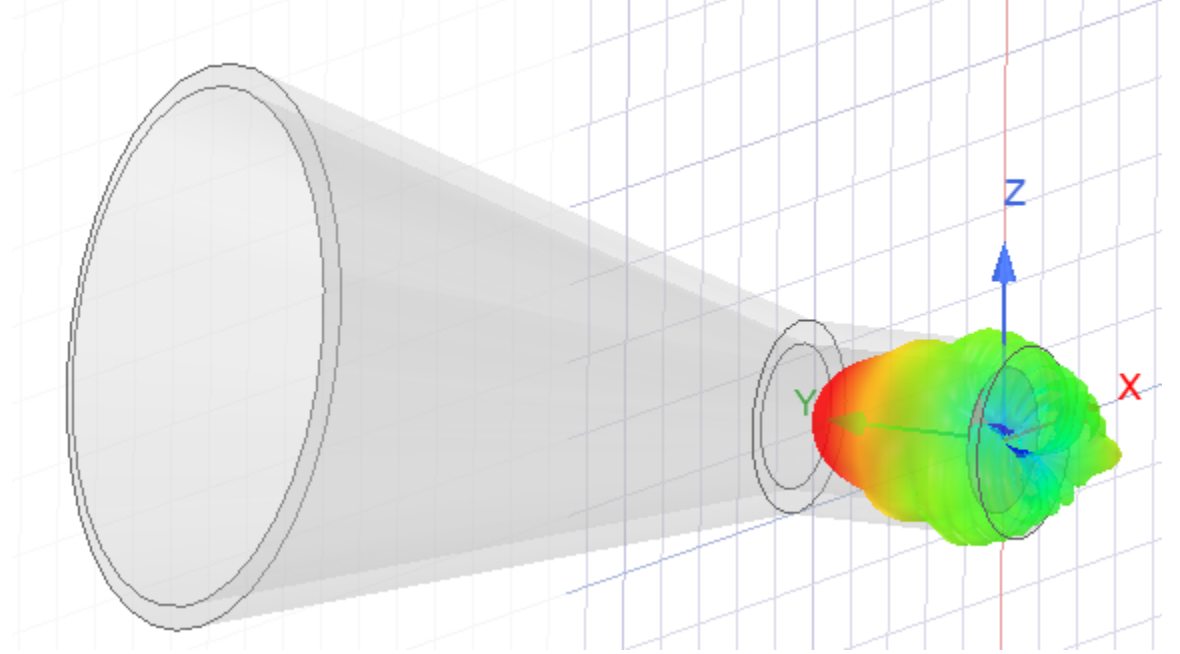
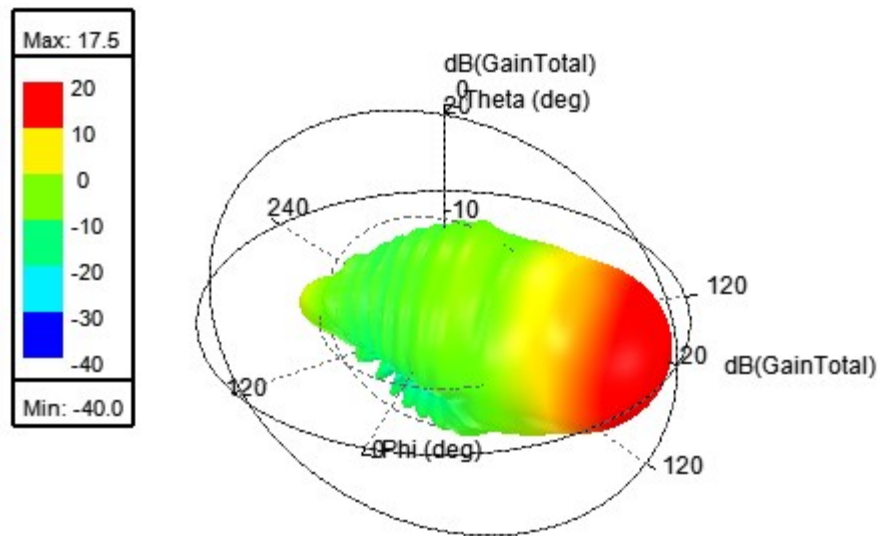

# Bibliografie

<https://www.youtube.com/watch?v=0w3cvOHYdiA>

<https://www.youtube.com/watch?v=4gyM1RHj6Sk>

[https://www.ets-lindgren.com/get-manuals/3160\(1\).pdf](https://www.ets-lindgren.com/get-manuals/3160(1).pdf)

<https://hrcak.srce.hr/file/203404>

<https://manualzz.com/doc/29697004/circular-and-rectangular-horn-antennas>

<https://www.youtube.com/watch?v=MjqXvERSQXg>